



STEAM SCRUBBER FILTER

STEAM SCRUBBER STAINLESS STEEL FILTER

SIZES 1/2" to 3"

PRESSURES to 145 PSIG at 353°F

- 1 and 5 Micron Filters meet or exceed FDA guidelines and comply with 3A
- Electropolished and Passivated 304 Stainless Steel Housing
- Double O-ring EPDM Housing Gasket
- Inline NPT Connections
- Single Clamp Closure
- Sintered 316 Stainless Steel Filter Media
- Porosity Level greater than 50%
- Filter Media in 1, 5 or 25 Micron Absolute Ratings
- Filter Element Endcaps of 304 Stainless Steel
- Renewable Filter Media
- Single Open End Filter Media

APPLICATION DATA

- Culinary Grade Steam
- Sterilizers
- Autoclaves
- Pharmaceutical & Biotechnology Process Equipment
- Clean Room Humidification
- Chemical Industry
- Electronic Industry
- Plastic Industry

OPTIONS

- 316L Housing
- Silicone, Viton or Buna N Gaskets
- Flange or Welded Ends
- 4" to 8" with ANSI Flanged End

Canadian Registration #OE8186.80

MODELS

- SS2L-2" low capacity
- SS3L-3" low capacity
- SS12-1/2" standard capacity
- SS34-3/4" standard capacity
- SS1-1" standard capacity
- SS114-11/4" standard capacity
- SS112-11/2" standard capacity
- SS2-2" standard capacity
- SS212-21/2" standard capacity
- SS3-3" standard capacity

NOTE: Please specify if Material Test Reports (MTR) or Certificates of Conformance (COC) are required.

**REQUIRES DRIP TRAP.
COMBINE WITH DS200 TRAP
FOR MOST CLEAN STEAM APPLICATIONS**

DS200 TRAP
PAGE 340

Installation Tip: Add Uniflex Pipe Coupling for ease of maintenance
SEE PAGE 374

STEAM SCRUBBER STAINLESS STEEL FILTER

SPECIFICATION

Furnish and install as shown on the plans, high efficiency, inline horizontal, filter for air, steam or gas constructed with 304 or 316L stainless steel housing and single, open ended element. Filter shall have an absolute rating of 1, 5 or 25 microns and utilize double o-ring gaskets to reduce potential downstream leakage of unfiltered medium. External surface finish of filter housing shall be no less than 180 grit (25-35 Ra microinch) and joined utilizing a single clamp. Filter media shall be of sintered 316L stainless steel and be regenerable. 1 and 5 micron media shall conform to 3A sanitary standards for production of culinary steam and be USDA accepted. Connections shall be NPT, flanged ANSI 150 or welded.

MAXIMUM OPERATING CONDITIONS*

PMO: Max. Operating Pressure	145 psig (10 barg)
Steam	Limit for Saturate
	125 psig (8.6 barg)
TMO: Max. Operating Temperature	353°F (178°C)
PMA: Max. Allowable Pressure	232 psi/g0-400°F
	(16 barg/0-204°C)
TMA: Max. Allowable Temperature	400°F/0-232 psig
	(204°C/0-16 barg)

*For differential pressures greater than 75 psig, consult factory.

MATERIALS OF CONSTRUCTION

Body, Standard	304 Stainless Steel
Body, Optional	316L Stainless Steel
Clamp	304 Stainless Steel
Plug	304 Stainless Steel
Gasket, Standard	EPDM
Gasket, Optional	Silicone
Gasket, Optional	Viton
Gasket, Optional	Buna N
Filter Media	Sintered 316L Stainless Steel
Filter End Caps	304 Stainless Steel

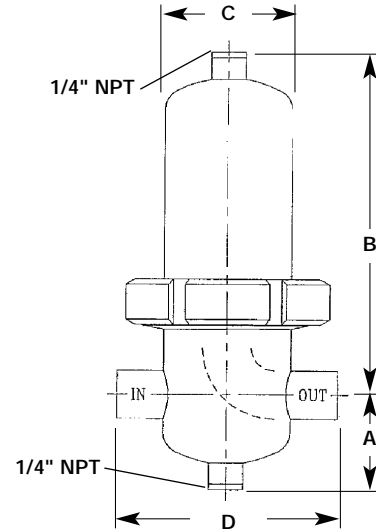

Connections:
1/2" – 3" NPT, Flanged or Welded

Saturated Steam Capacity — 2"L, 250°F, 15 PSI (Cm)*

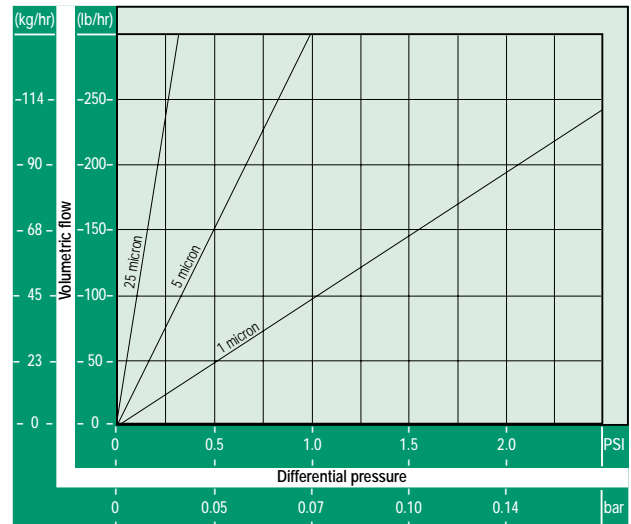

*For other pressures and sizes, see conversion factors.

DIMENSIONS AND WEIGHTS

Size in.(mm)	Dimensions, Inches (mm)				Weight lbs (kg)	Conversion Factors (Cs)
	A	B	C	D		
1/2 (15)	2 1/8 (55)	7 3/8 (188)	2 3/4 (70)	4 1/8 (108)	4.2 (1.9)	0.17
3/4 (20)	2 1/8 (55)	8 3/8 (211)	2 3/4 (70)	4 7/8 (125)	4.4 (2.0)	0.25
1 (25)	2 1/8 (74)	8 5/8 (219)	3 3/8 (85)	4 7/8 (125)	5.7 (2.6)	0.39
1 1/4 (32)	2 1/8 (74)	10 5/8 (270)	3 3/8 (85)	5 1/2 (140)	6.6 (3)	0.50
1 1/2 (40)	3 3/4 (94)	11 1/2 (292)	4 1/8 (104)	6 5/8 (170)	10.1 (4.6)	0.67
2L* (50)	3 3/4 (94)	14 3/8 (366)	4 1/8 (104)	6 5/8 (170)	10.6 (4.8)	1.00
2 (50)	3 3/4 (94)	19 3/8 (493)	4 1/8 (104)	6 5/8 (170)	11.7 (5.3)	1.50
2 1/2 (65)	4 1/4 (106)	24 5/8 (626)	5 1/8 (129)	8 1/2 (216)	19.8 (9)	2.00
3L* (80)	4 1/4 (106)	34 5/8 (881)	5 1/8 (129)	8 1/2 (216)	23.8 (10.8)	2.70
3 (80)	4 7/8 (119)	35 3/4 (907)	6 (154)	9 3/8 (240)	35.6 (16.2)	4.00

* L denotes low capacity

SELECTION EXAMPLE

For optimum service life, the filter should have a 1 psi maximum pressure drop. Select a 5 micron filter for a flow rate of 110 lbs/hr (w) of saturated steam at 45 psi.

$$\text{Where: } Cs = \frac{w}{CmCp}$$

Designing for .75 PSI differential pressure, Cm is 225 from the capacity chart and Cp is 2.0.

$$\text{Therefore: } Cs = \frac{110}{(225)(2.0)} = .24 \text{ so } 3/4" \text{ should be used.}$$

Steam Pressure Conversion Factors (Cp)											
Steam Pressure	PSI	0	15	30	45	60	75	90	105	120	135
bar	0	1	2	3	4	5	6	7	8	9	
Conversion factor	0.5	1.0	1.5	2.0	2.5	3.0	3.5	4.0	4.5	5.0	