

DW
PADDLE-BELLOWS FLOWMETER & SWITCH

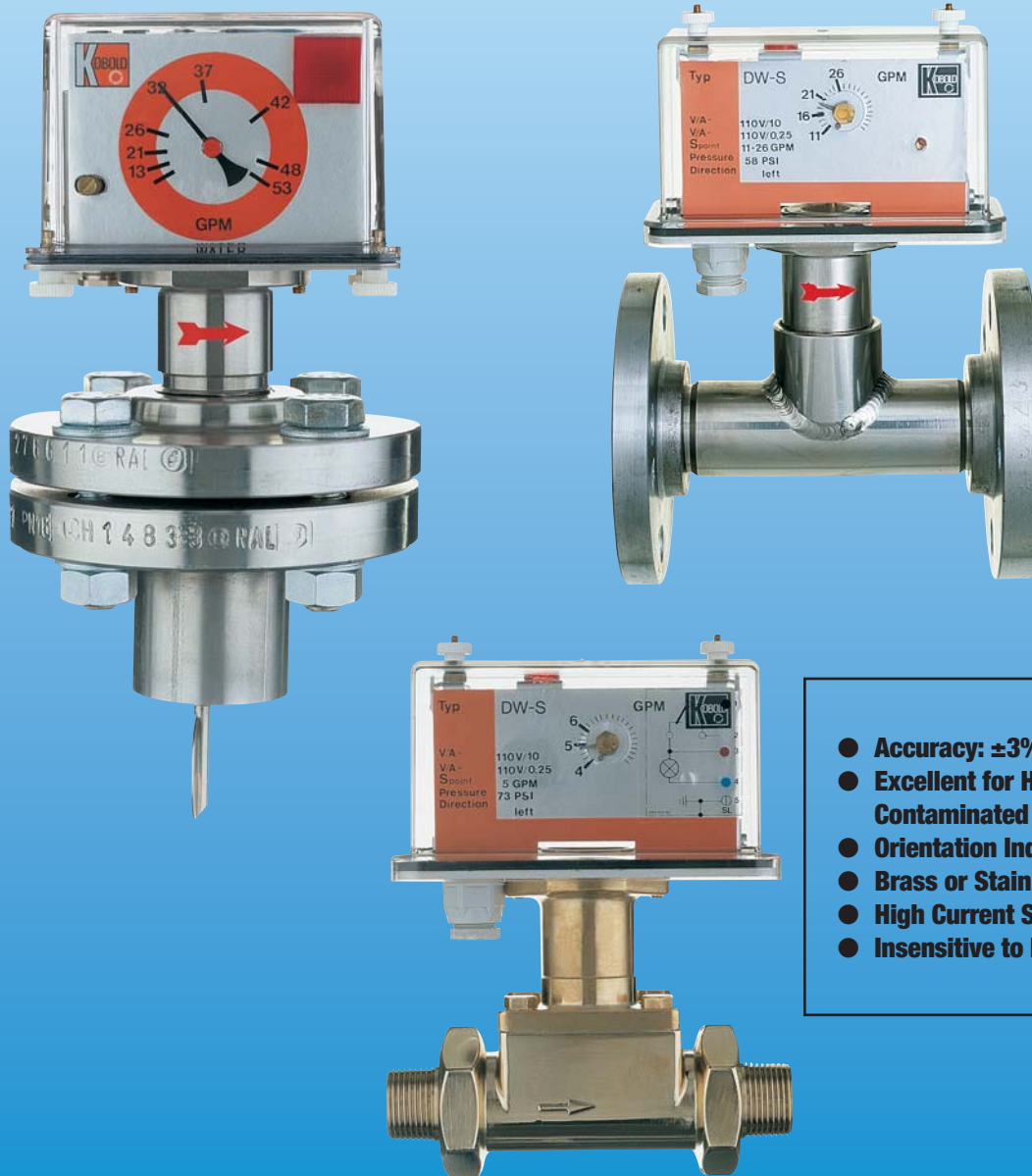

Flow
 Pressure
 Level
 Temperature
 measurement
 monitoring
 control



S3

- Accuracy: ±3% Full Scale
- Excellent for Highly Contaminated Media
- Orientation Independent
- Brass or Stainless Steel
- High Current Switching Capability
- Insensitive to Magnetic Fields

 **USA**
 KOBOLD Instruments Inc.
 1801 Parkway View Drive
 USA-Pittsburgh, PA 15205
 ♦ +1 412-788-2830
 Fax +1 412-788-4890
 E-mail: info@koboldusa.com

 **CANADA**
 KOBOLD Instruments Canada Inc.
 9A Aviation
 Pointe-Claire, QC H9R 4Z2
 ♦ +1 514-428-8090
 Fax +1 514-428-8899
 E-mail: kobold@kobold.ca

Visit KOBOLD Online at
www.kobold.com

Model:
 DW

Features

- Accuracy: ± 3 % of full scale
- Excellent for Highly Contaminated Media
- Orientation Independent
- Brass or Stainless Steel
- High Current Switching Capability
- Insensitive to Magnetic Fields

KOBOLD model DWU, DWS and DWP flow meters and switches are based on the paddle, or static plate, principle. This type of arrangement is ideal for use in applications where dirt and solid grain contaminant are of concern. The paddle-bellows arrangement offers large internal clearances and mechanical insensitivity to a wide range of particulate matter.

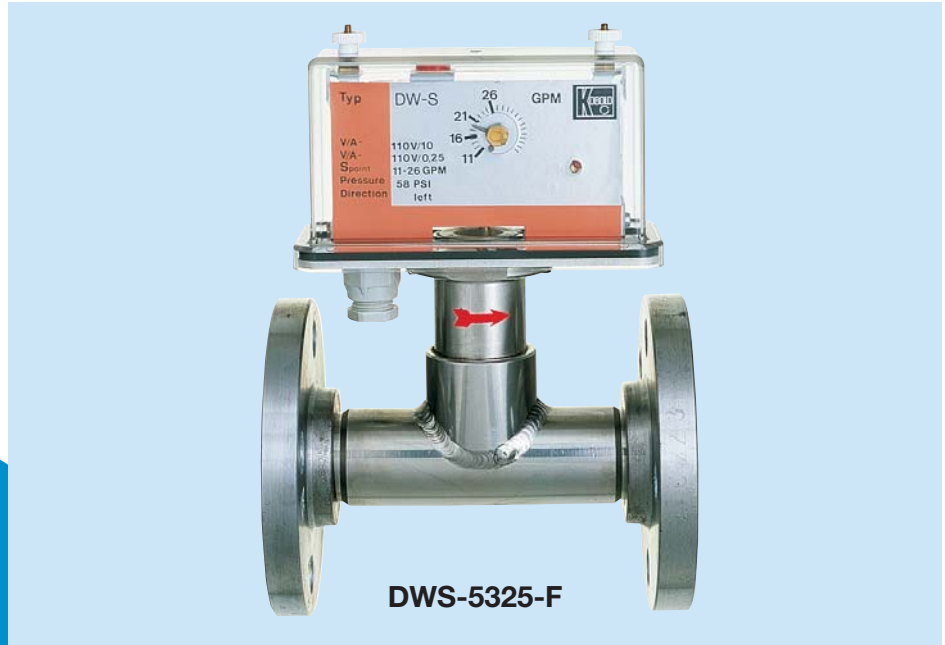

Specifications

Accuracy

- 0 to 6 GPM:** ± 5 % of full scale
- 6 to 60 GPM:** ± 4 % of full scale
- Over 60 GPM:** ± 3 % of full scale

Flow Media:

Liquids

Flow Range:

0.65 to 18 ft/sec

Max/Min Ratio

- 2" & Smaller:** 5:1
- 2 1/2" Larger:** 4:1

Pressure Loss:

1.5 to 7.5 PSI

Fittings:

Male threads, 150 lb rf flanges, or insertion style

Microswitch:

1 or 2 SPDT

Maximum Load:

10 A @ 250 VAC

Hysteresis:

± 10 %

Lamp:

N/C (on)

Protection:

NEMA 4

Installation:

Vertical or horizontal.

Straight pipe requirements are:

10x inner pipe diameter upstream of meter and 5x inner pipe diameter downstream.

Material Combination Component	Material	
	0200	0300
T-piece	Brass	316-Ti SS
Paddle	Brass	303 SS
Bellows	316-Ti SS	316-Ti SS
Housing: Measuring Section	Matte Aluminum	
Housing: Cover	Clear Polycarbonate	
Flanges (on flanged units)	Galvanized Steel	316 SS
Maximum Operating Pressure	145 PSIG	145 PSIG
Maximum Operating Temperature	210 °F	
Maximum Ambient Temperature	160 °F	

The DW series of flowmeters comes in a variety of mounting styles. Units are available for in-line installation into pipes to 2" with either threaded or flanged ends. For larger pipe applications, the DW is available in a "weld-on" design usable on pipes with diameters up to 24 inches.

NPT Fittings

All Kobold DW models (DWU, DWS and DWP) are available with NPT threads for in-line installation. NPT threads are standard on all DWx-5000 series flowmeters (see DWS-5120 to the left.) Thread sizes range from 3/8" to 2" NPT.

DWU-7300: Weld-On Flange



DWS-5120: 3/4" NPT

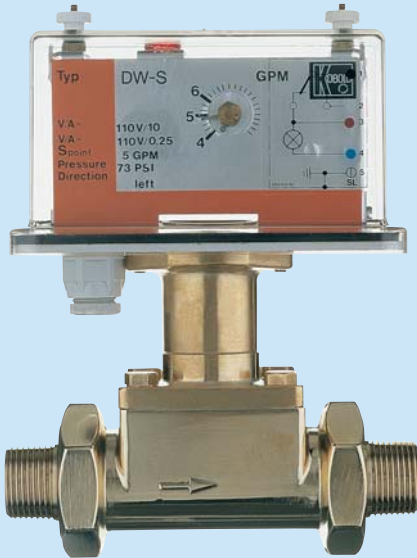

Flanged Fittings

The basic model DWx-5000 meters are also available with 150 lb rf ANSI flanges in place of NPT threads. To order the meter with flanges, simply add »-F« to the part number of the unit which best suits your application. Flanges, such as on the DWS-5325-F shown in the lower left, make post-installation removal of the unit a breeze . . . your maintenance people will be impressed.

Weld-On Flange Fitting

Kobold's DW series meters may be used with pipes having internal diameters up to 24 inches. This is made possible through use of the DW in an insertion-style configuration. Insertion is achieved through installation of a weld-on, flanged collar (supplied with the meter.) The collar is provided in either galvanized carbon steel for brass units, or 316 SS for stainless steel units.

DWS-5325-F: 1" Flange



Installation Diagram for Weld-On Flanges

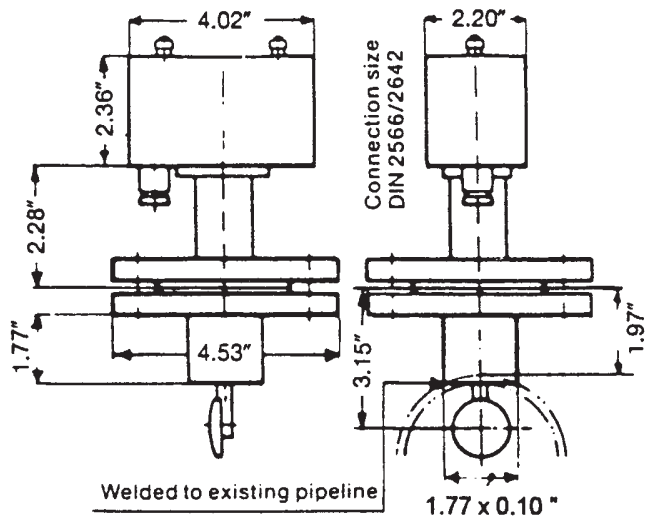

S3

How to Order:

1. Determine required range. The DW series allows you free choice of either the minimum or maximum range value. Once chosen, the range will have a Max./Min. ratio of 5:1 for units 2" and smaller, and 4:1 for units above 2".
2. Select the part number for the style of meter and material combination you require.

3. Add desired options to the part number as suffixes (options are found in the table on the previous page.)

In addition to the part number, there is some application information we need in order to build the DW according to your wishes.

- Type of liquid.
- Pressure, temperature, density and viscosity of liquid during operation.
- Desired range from table.
- Flow direction (←, →, ↑, ↓).
- Power requirements for lamp.
- Pipe diameter.
- For vertical pipes, specify: housing right of pipe (|—○), or housing left of pipe (○—|).

Operation

The simplicity of the DW series design is its major asset. The devices operate as follows:

The flow causes the paddle, or static plate (1) to be deflected in the direction of flow against the force of a spring (2). A bellows (3), made of bronze (or preferably stainless steel), hermetically isolates the medium from the measuring/indicating section. The motion of the paddle (1) is transmitted directly to a pointer (4) or transducer. The pointer (4) indicates the flow in GPM, or transmits the signal to a signal conditioner. A MicroSwitch® (6) and an indicating lamp (7) are actuated when the setpoint is reached. The lamp is active when the flow is below the setpoint. The SPDT microswitch may be used with currents up to 10 A at 250 VAC.

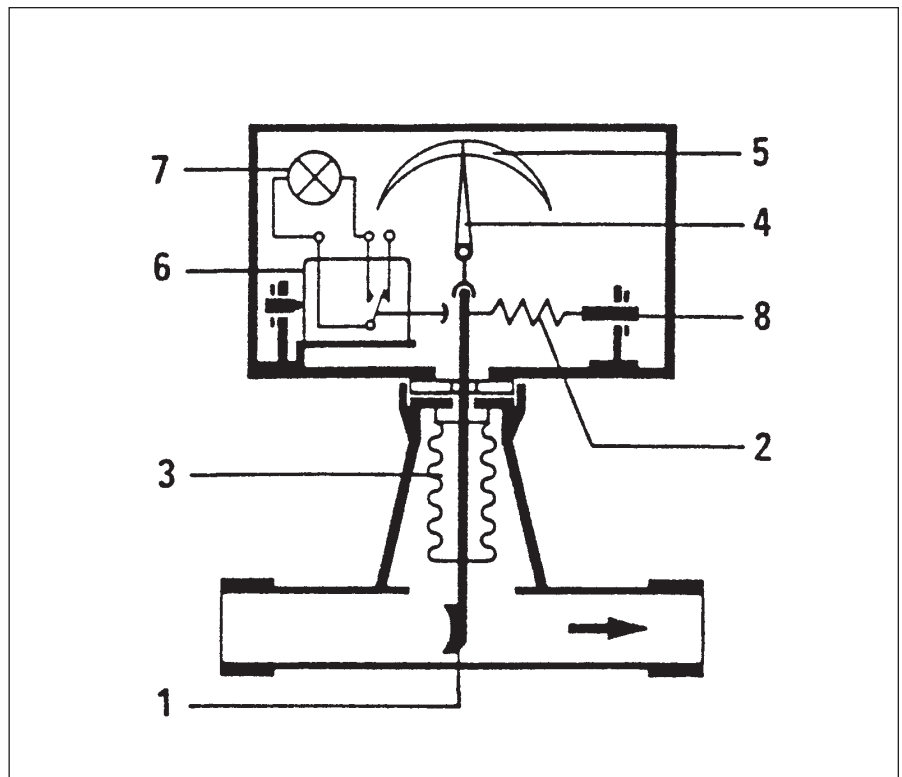

Analog Output Option

For installations requiring remote indication of flow, we offer the DW series of flowmeters with optional analog output (option »-AN«). The meter continues to function in the standard way, except that the mechanical dial movement is replaced by an inductive motion transducer. The transducer is connected to a transmitting device which converts the sensor movement into a 4–20 mA signal.

For units supplied with analog output, the mechanical indicator is replaced with an 8 digit LCD display.

Switching capability is not part of the standard configuration with option -AN analog output meters. If switching capability is desired in addition to the analog output, two setpoint relays can be provided as part of the transmitter electronics (option-K1).



S3

Option Ordering Information

Description	Available on...	Ordering Suffix
2 Setpoint Relays (for Analog Output Option only)	DWU only	-K1
Second SPDT Microswitch®	All meters	-K2
Gold Plated Contacts	All meters	-G
230 PSIG Service Pressure (only materials 0200 & 0300)	DWU & DWS	-H
4–20 mA, Analog Output & LCD Display	DWU only	-AN1
24 VDC Power Supply For Status Lamps	DWU only	-P11
110 VAC Power Supply For Status Lamps	DWU only	-P12
220 VAC Power Supply For Status Lamps	DWU only	-P13

Specifications (Analog Output)

Output:	4–20 mA, 4-wire
Load:	0–500 ohm
Display:	LCD 8 digit, standard with option-AN1
Adjustments	
Zero:	± 4 %
Span:	± 10 %
Supply:	24 VDC ± 10 %
Relays (optional)	
Type:	0, 1 or 2 SPDT
Max. Load:	1 A @ 230 VAC
Lamp:	None
Maximum Temperature	
Liquid:	212 °F
Ambient:	160 °F
Protection:	NEMA 4



Ordering Information for NPT and Flanged Units

Fitting (NPT)	Range		Flowmeter + Switch Material Combination		Adjustable Flow Switch Material Combination		Factory Set Flow Switch Material Combination	
	Min (GPM)	Max (GPM)	0200	0300	0200	0300	0200	0300
3/8"	0.26– 1.3	1.3– 6.6	DWU-5210	DWU-5310	DWS-5210	DWS-5310	DWP-5210	N/A
1/2"	0.79– 2.9	4.0– 14.5	DWU-5215	DWU-5315	DWS-5215	DWS-5315	DWP-5215	N/A
3/4"	1.3 – 5.3	6.5– 26.4	DWU-5220	DWU-5320	DWS-5220	DWS-5320	DWP-5220	N/A
1"	1.6 – 7.9	8.0– 39.6	DWU-5225	DWU-5325	DWS-5225	DWS-5325	DWP-5225	N/A
1 1/4"	2.6 –13.2	13.0– 66.0	DWU-5232	DWU-5332	DWS-5232	DWS-5332	DWP-5232	N/A
1 1/2"	5.3 –21.2	26.5–106	DWU-5240	DWU-5340	DWS-5240	DWS-5340	DWP-5240	N/A
2"	13.2 –31.6	66.0–158	DWU-5250	DWU-5350	DWS-5250	DWS-5350	DWP-5250	N/A

For 150 lb rf ANSI Flange Fittings, add suffix »-F« to part number. N/A= Not Available

Ordering Information for Weld-On Units

Pipe Bore	Range		Flowmeter + Switch	Adjustable Flow Switch	Factory Set Flow Switch
	Min (GPM)	Max (GPM)			
1 1/2"	5.3– 21.2	26.5– 106	Material Combination 0200: DWU-7200	Material Combination 0200: DWS-7200	Material Combination 0200: DWP-7200
2"	13.2– 31.6	66.0– 158			
2 1/2"	21.1– 66.0	84.4– 264			
3"	31.7– 99	127 – 396			
4"	52.8– 158	211 – 633			
5"	79.2– 265	317 – 1060	Material Combination 0300: DWU-7300	Material Combination 0300: DWS-7300	Material Combination 0300: N/A
6"	105 – 363	420 – 1450			
8"	185 – 660	740 – 2640			
10"	317 – 990	1268 – 3960			
12"	449 –1320	1800 – 5280			
14"	660 –1980	2640 – 7920			
16"	792 –2650	3170 –10600			
20"	1320 –3950	5280 –15800			
24"	1850 –4950	7400 –19800			

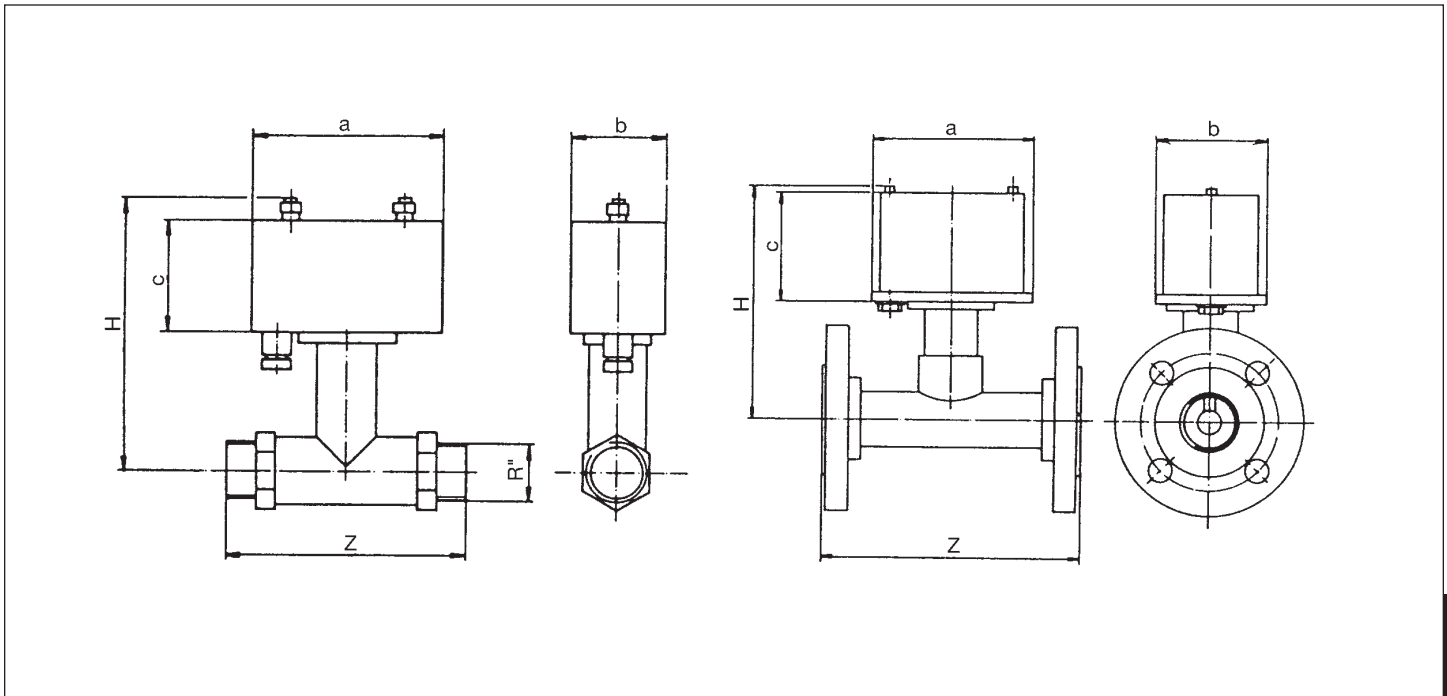

S3

DWP Series Dimensions (mm)

Pipe Size, R (Nominal)	3/8"	1/2"	3/4"	1"	1 1/4"	1 1/2"	2"
Dimension Z (Length) with NPT Fittings	110 ± 1	130 ± 1	135 ± 1	135 ± 1	170 ± 2	170 ± 2	170 ± 2
Dimension Z (Length) with ANSI Flange	130 ± 2	155 ± 2	160 ± 2	160 ± 2	190 ± 2	190 ± 2	190 ± 2
Dimension H (Height)	145 ± 1	145 ± 1	145 ± 1	145 ± 1	145 ± 2	150 ± 2	155 ± 2
Housing: a×b×c	100×70×70						

DWS Series Dimensions (mm)

Pipe Size, R (Nominal)	3/8"	1/2"	3/4"	1"	1 1/4"	1 1/2"	2"
Dimension Z (Length) with NPT Fittings	135 ± 1	135 ± 1	135 ± 1	135 ± 1	170 ± 2	170 ± 2	170 ± 2
Dimension Z (Length) with ANSI Flange	155 ± 2	155 ± 2	160 ± 2	160 ± 2	190 ± 2	190 ± 2	190 ± 2
Dimension H (Height)	155 ± 1	155 ± 1	155 ± 1	155 ± 1	160 ± 2	165 ± 2	170 ± 2
Housing: a×b×c	100×50×80						

DWU Series Dimensions (mm)

Pipe Size, R (Nominal)	3/8"	1/2"	3/4"	1"	1 1/4"	1 1/2"	2"
Dimension Z (Length) with NPT Fittings	135 ± 1	135 ± 1	135 ± 1	135 ± 1	170 ± 2	170 ± 2	170 ± 2
Dimension Z (Length) with ANSI Flange	155 ± 2	155 ± 2	160 ± 2	160 ± 2	190 ± 2	190 ± 2	190 ± 2
Dimension H (Height)	145 ± 1	145 ± 1	145 ± 1	145 ± 1	150 ± 2	155 ± 2	160 ± 2
Housing: a×b×c	100×70×70						



<p>DW Series Flowmeters Application Guide Form # DW-001 Rev. 11/01/01</p> <p>FAX to: KOBOLD Instruments Inc. 412-788-4890 (USA) 514-428-8899 (Canada)</p>	<p>Customer Name: _____</p> <p>Company Name: _____</p> <p>Phone: _____</p> <p>Fax: _____</p>
-----------------------------------------------------------------------------------------------------------------------------------------------------------------------------------------------------------------------------------	--------------------------------------------------------------------------------------------------------------------------

Quote #: _____ Date: _____ Price: _____ Each

Part Number: _____ * To ensure fast order processing, please retain the completed quote form and send it along with your purchase order.

Calibrated Measuring Range: _____

Design Conditions

Accurate design pressure and temperature are essential to ensure the flowmeter will be built to operate without damage. Please fill out accurately and completely.

List Design Conditions

- 1. **Pressure:** Maximum _____ PSIG
- 2. **Temperature:** Maximum _____ °F

Calibration Conditions: Accurate calibration conditions are required to ensure that the flowmeter will be factory calibrated to give accurate readings at the user's **normal operating conditions**. Please fill out accurately and completely.

Calibration Conditions for Liquid Flow Applications

- 1. **Type of Liquid:** _____
- 2. **Normal Operating Temperature:** _____ °F
- 3. **Viscosity at Normal Operating Temp:** _____
- 4. **Specific Gravity at Normal Operating Temp:** _____
- 5. **Normal Operating Pressure:** _____ PSIG
- 6. **Desired Measuring Range and Units:** _____

Note: Items 3 & 4 not required for water flow

Desired Flow Range and Measuring Units

The DW series allows you to chose either the maximum or minimum measuring range value from the Min. and Max. ranges listed in the ordering information tables of the DW series specification sheets. Once chosen, the meter will have a Max./Min. ratio of 5:1 for pipe sizes 2" and smaller and 4:1 for pipe sizes above 2".

Desired Flow Range and Measuring Units: _____

Flowmeter Options

1. Material Combinations:

- 0200 = 316 SS bellows, brass paddle, brass body, steel flanges (for flanged or weld on units)
- 0300 = 316 SS bellows, 303 SS paddle, 316 SS body, 316 SS flanges (for flanged or weld on units)

2. Line size (specify): _____

3. Fitting style:

- NPT thread (only for 2" lines or smaller)
- 150 LB ANSI flange (2" lines or smaller)
- Weld on insertion paddle (for 1-1/2" to 24" lines)

4. Flow Direction (right, left, up or down): _____

5. Indicator Orientation, dial on the right or left side pipe. Only required for up or down flow: _____

Other Options:

- 1. 4-20 mA transmitter w/ LCD display (relays are optional with this version)
- 2. 4-20 mA transmitter w/ LCD display and 2 setpoint relays
- 3. 230 PSIG service pressure rating
- 4. Gold Plated Contacts
- 5. 24 VDC power for indicator lamp
- 6. 110 VAC power for indicator lamp
- 7. 220 VAC power for indicator lamp