



## Type 55 Butterfly Valves

### Standard Features

- Highly corrosion resistant PTFE disc and seat
- Epoxy powder coated ductile iron body for corrosive atmosphere or environments
- Strong but thin disc with high Cv value
- Stainless steel stem has full engagement over the entire length of the disc and is a non-wetted part, totally isolated from the media
- Only PTFE disc and PTFE seat are wetted parts
- Bubble-tight shut-off
- Rated for full vacuum service
- Locking device
- 18 position throttle plate for lever handle style

### Options

- Pneumatically or electrically actuated with accessories
- Gear operators for 2" – 5"
- 2" square nut on valve stem
- 2" square nut on gear
- Stem extensions (single stem and two-piece stem)
- Chain operators
- Manual limit switch

### Caution

- Never remove valve from pipeline under pressure.
- Always wear protective gloves and goggles.

### Specifications

**Sizes:** 2" – 10"

**Models:** Wafer Style

**Operators:** Lever: 2" – 5"  
Gear: 2" – 10"

**Bodies:** Epoxy powder coated ductile cast iron

**Discs:** PTFE

**Seats:** PTFE backed with Neoprene®†

**Seals:** Same as seating material

**Stems:** Stainless steel 304

† Trademarks of E. I. du Pont de Nemours and Company

### Parts List (Lever: Sizes 2" – 5")

PARTS			
NO.	DESCRIPTION	PCS.	MATERIAL
1	Body	1	Ductile Cast Iron*
2	Disc	1	PTFE
2a	Disc Insert	1	Stainless Steel 304
3	Seat	1	PTFE
3a	Cushion Rubber	1	CR
4	Stem	1	Stainless Steel 304
5	Bush	2	Stainless Steel 304
6	O-Ring	2	EPDM
7	Bolt (A)	-	Stainless Steel 304
11	Cap	1	PP
12	Handle	1	PP
12a	Handle Metal Insert	1	Stainless Steel 316
13	Handle Lever	1	PPG
14	Pin	1	PPG
15	Spring	1	Stainless Steel 304
16	Washer	1	Stainless Steel 304
17	Bolt (C)	1	Stainless Steel 304
18	Locking Plate	1	PPG
19	Screw	4	Stainless Steel 304

\*With epoxy powder coating



# Type 55

# Lever Butterfly Valves

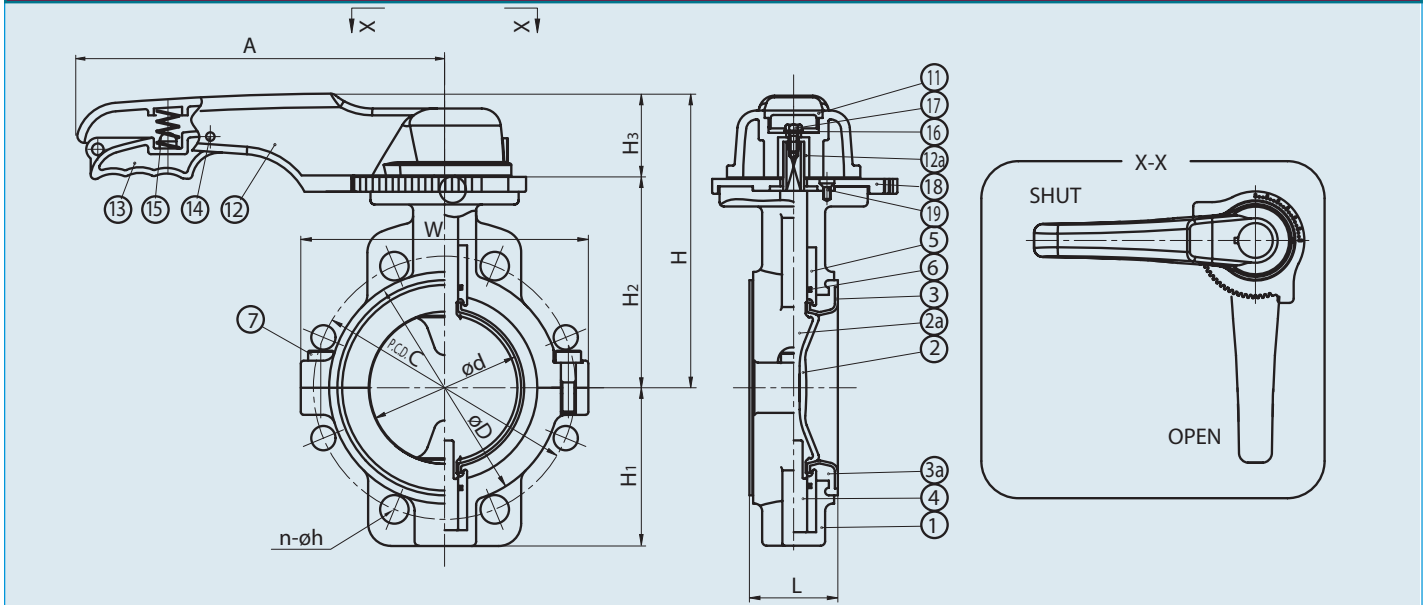

## Dimensions (Sizes 2" – 5")

NOMINAL SIZE		ANSI Class 150											
INCHES	mm	d	C	n	h	D	L	H	H1	H2	H3	W	A
2	50	2.17	4.75	2(4)	0.75	3.54	1.73	6.34	2.40	4.13	2.20	4.57	8.66
3	80	3.15	6.00	2(4)	0.75	4.92	2.13	7.09	3.74	4.88	2.20	5.98	9.84
4	100	3.94	7.50	4(8)	0.75	6.06	2.32	7.72	3.90	5.51	2.20	6.85	9.84
5	125	4.92	8.50	4(8)	0.88	7.13	2.52	9.25	4.72	6.54	2.72	8.11	12.60

## Cv Values

NOMINAL SIZE		Cv
INCHES	mm	
2	50	100
3	80	285
4	100	600
5	125	940
6	150	1500
8	200	2500
10	250	4200

## Weight (POUNDS)

NOMINAL SIZE		LEVER	GEAR
INCHES	mm		
2	50	6.61	11.02
3	80	9.92	14.33
4	100	13.23	17.64
5	125	23.15	25.35
6	150	-	31.97
8	200	-	50.71
10	250	-	73.85

## Pressure vs. Temp.

NOMINAL SIZE		-5° F 210° F
INCHES	mm	
2	50	150
3	80	150
4	100	150
5	125	150
6	150	150
8	200	150
10	250	150

## Troubleshooting

### What if fluid still flows when valve is closed?

1. Make sure lever or gear is in a fully closed position (gear type may require travel stop adjustment).
2. Liner is damaged or worn. Replace liner.
3. Disc is damaged or abraded. Change disc.
4. Foreign material is caught between seat and disc. Remove the substance.
5. Mating flange bolts either over-tightened or unevenly tightened. Retighten properly.

### What if fluid leaks outside between seat and mating flange?

1. Seat damage. Change seat.
2. Mating flange bolts not tightened to proper torque or unevenly tightened. Retighten to the appropriate torque.

### What if valve does not operate smoothly?

1. Foreign material is caught between disc and seat. Remove the material and clean.
2. Lever or gearbox is damaged. Replace.
3. Mating flange bolts over-tightened. Retighten.

# Type 55

# Gear Butterfly Valves

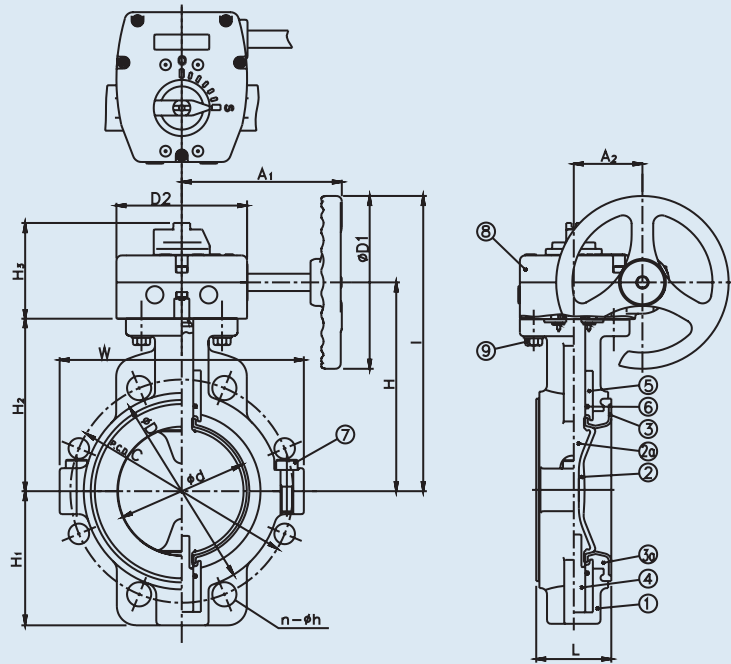

## Dimensions (Sizes 2" – 10")

NOMINAL SIZE		ANSI Class 150				D	D1	L	H	H1	H2	H3	l	W	A	A1
		d	C	n	h											
INCHES	mm	d	C	n	h	D	D1	L	H	H1	H2	H3	l	W	A	A1
2	50	2.17	4.75	2(4)	0.75	3.54	6.30	1.73	5.29	2.40	3.94	3.54	8.49	4.57	6.57	2.52
3	80	3.15	6.00	2(4)	0.75	4.92	6.30	2.13	6.04	3.74	4.69	3.54	9.24	5.98	6.57	2.52
4	100	3.94	7.50	4(8)	0.75	6.06	6.30	2.32	6.66	3.90	5.31	3.54	9.86	6.85	6.57	2.52
5	125	4.92	8.50	4(8)	0.88	7.13	6.30	2.52	7.57	4.72	6.22	3.54	10.77	8.11	6.57	2.52
6	150	5.91	9.50	4(8)	0.88	8.31	6.30	2.95	8.24	5.39	6.89	3.54	11.44	9.29	6.57	2.52
8	200	7.52	11.75	4(8)	0.88	10.43	6.30	3.35	9.42	6.42	8.07	3.54	12.62	11.10	6.57	2.52
10	250	9.65	14.25	4(12)	1.00	12.80	6.30	3.78	10.80	7.87	9.45	3.54	14.00	13.43	6.57	2.52

## Parts List (Gear: Sizes 2" – 10")

PARTS			
NO.	DESCRIPTION	PCS.	MATERIAL
1	Body	1	Ductile Cast Iron*
2	Disc	1	PTFE
2a	Disc Insert	1	Stainless Steel 304
3	Seat	1	PTFE
3a	Cushion Rubber	1	CR
4	Stem	1	Stainless Steel 304
5	Bush	2	Stainless Steel 304
6	O-Ring	2	EPDM
7	Bolt (A)	-	Stainless Steel 304
8	Gear Box	1	Plasgear™
9	Bolt (B)	4	Stainless Steel 304

\*With epoxy powder coating

## Sample Specification

All Type 55 butterfly valves shall be of epoxy powder coated ductile cast iron body design and bubble-tight seal (meeting or exceeding Class VI as defined by American National Standard Institute) with only the liner and disc as wetted parts. The lever handle (sizes 2" thru 5") shall have a molded provision for a padlock. Gear operators shall be worm gear design, self-locking, with Plasgear, plastic gear box. Valves shall have a molded ISO bolt pattern conforming to 5211/I and 5211/II on top flange for actuator mount. The disc shall be of PTFE. Liner shall be of PTFE with Neoprene® backing cushion. Stem shall be of stainless steel, not wetted and have engagement over the full length of the disc. The butterfly valves shall be wafer style, Valves shall be rated to 150 psi from -5 degrees F. to +210 degrees F., as manufactured by Asahi/America, Inc.