

Type 56 Butterfly Valves

Specifications

Sizes:	Gear: 16"
Models:	Wafer Style
Operators:	Gear
Bodies:	PP and PVDF
Discs:	PP and PVDF
Seats:	EPDM or FKM, Also Nitrile,
Seals:	Same as seating material
Stems:	403 and 316 stainless steel, Titanium, Hastelloy C [®] ‡, etc

Standard Features (Sizes 16")

- Standard model 16" has PP body and PP disc as standard.
- Our 403 stainless steel shaft has full engagement over the entire length of the disc and is a non-wetted part, totally isolated from the media.
- Only solid and abrasion-resistant plastic disc and elastomeric liner are wetted parts.
- ISO bolt circle on top flange
– no body or stem modifications required for accessories.

Options

- Pneumatically and electrically actuated with accessories
- Alternate disc: PVDF
- Lug style (stainless steel 304 or 316) as blocking and end-of-line applications
- Stems in 316 stainless steel, titanium, Hastelloy C[®], etc.
- 2" square nut on gear operator
- Stem extensions (single stem and two-piece stem)
- Locking devices
- Chain operators
- Manual limit switch - Asahi P-Series

Parts List (Gear: Size 16")

PARTS			
NO.	DESCRIPTION	PCS.	MATERIAL
1	Body	1	PP, PVDF
2	Disc	1	PP, PVDF
3	Seat	1	EPDM, FKM, NBR
4	O-Ring (A)	2	EPDM, FKM, NBR
5	O-Ring (B)	2	EPDM, FKM, NBR
6	O-Ring (C)	1	EPDM, FKM, NBR
7	Stem	1	Stainless Steel 403
25	Gear Box	1	Plasgear™
28	Bolt(C)	4	Stainless Steel 304
1a	Ring	2	Steel

Sample Specification

All solid thermoplastic butterfly valves sizes 16" shall be of lined body design and bubble-tight seal (meeting or exceeding Class VI as defined by American National Standard Institute) with only the liner and disc as wetted parts. Gear operators shall be worm gear design, self locking Plasgear. The disc shall be of solid, abrasion-resistant plastic, have double o-ring seals on top and bottom trunnions of the same material as the valve liner. Liner shall be molded and formed around the body, functioning as gasket seals with convex ring design on each side of the valve for lower bolt tightening torque. Stem shall be of 403 stainless steel, non wetted and have engagement over the full length of the disc. Valves shall have a molded ISO bolt pattern conforming to 5211/I – 5211/II on top flange for actuator mount. PP conforming to ASTM D4101 Cell Classification PP0210B67272, and PVDF conforming to ASTM D 3222 Cell Classification Type II. PP and PVDF body valves shall be rated 85 psi size 16" at 70 degrees F. Butterfly valves shall be wafer style, as manufactured by Asahi/America Inc.

Type 56 – Gear Operated Butterfly Valves

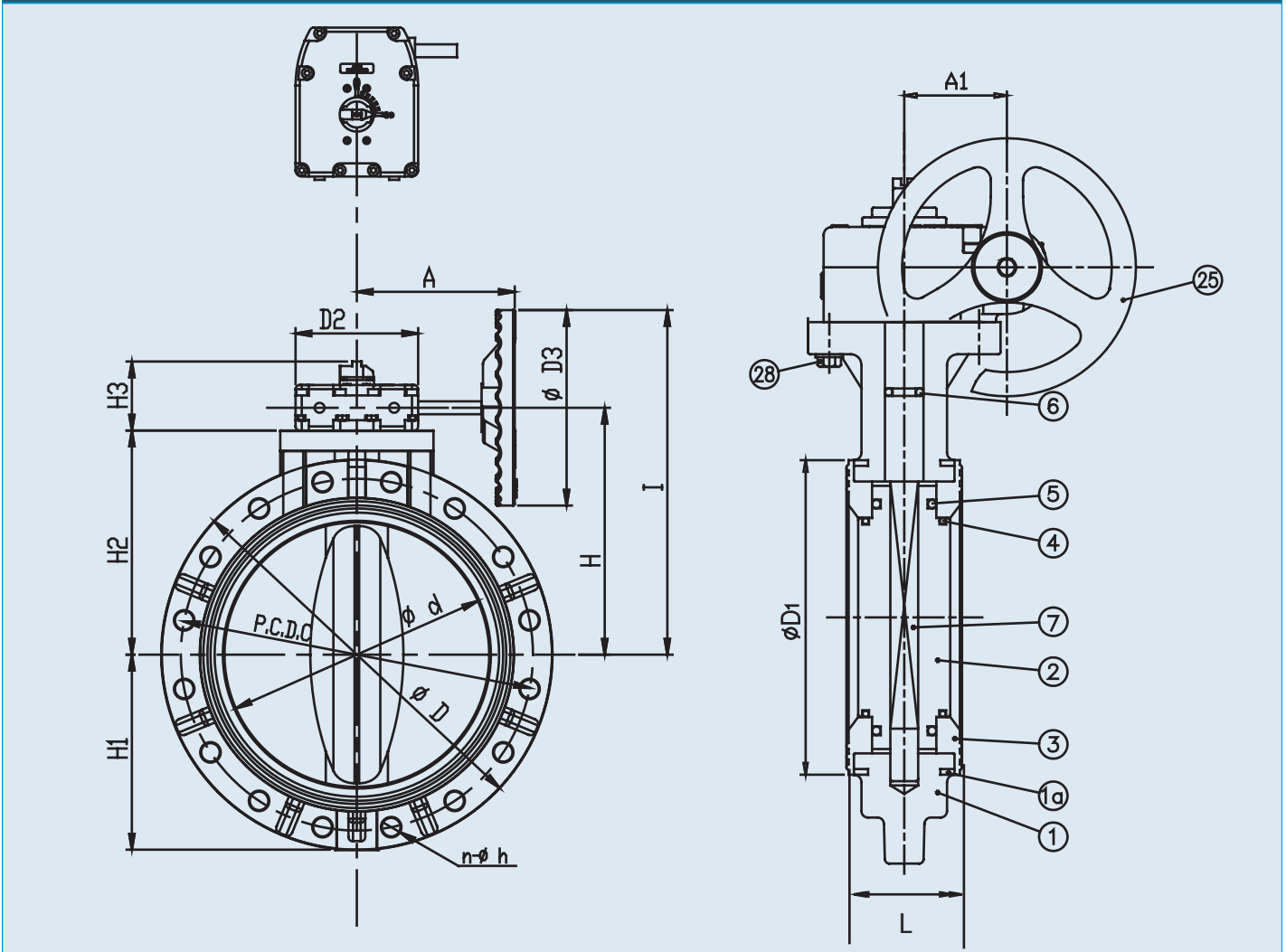

Dimensions (Sizes 16") Note: Gear operated valve is standard size 16"

NOMINAL SIZE		ANSI CLASS 150															Gear Box Model	
INCHES	mm	d	C	n	h	D	D1	D2	D3	L	H	H1	H2	H3	I	A		A1
16	400	15.98	21.25	16	1.12	23.62	18.50	7.40	11.81	6.65	14.92	11.81	13.54	4.25	20.82	10.71	3.90	243

Type 56 – Gear Operated Butterfly Valves

Troubleshooting

What if fluid still flows when valve is closed?

1. Make sure gear is in a fully closed position (may require travel stop adjustment).
2. Liner is damaged or worn. Replace liner.
3. Disc is damaged or abraded. Change disc.
4. Foreign material is caught between seat and disc. Remove the substance.
5. Mating flange bolts either over-tightened or unevenly tightened. Retighten properly.

What if fluid leaks outside between seat and mating flange?

1. Seat damage. Change seat.
2. Mating flange bolts not tightened with proper torque or unevenly tightened. Retighten to the appropriate torque.

What if valve does not operate smoothly?

1. Foreign material is caught between disc and seat. Remove the material and clean.
2. Gearbox is damaged. Replace.
3. Mating flange bolts over-tightened. Retighten.

Caution

- Never remove valve from pipeline under pressure.
- Always wear protective gloves and goggles.

Pressure vs. Temperature (PSI, WATER, NON-SHOCK)* Wt. (LBS) / Vacuum Service

BODY		PP		PVDF			
DISC		PP		PVDF			
NOMINAL SIZE		-5° F	141° F	-5° F	141° F	176° F	211° F
INCHES	mm	140° F	175° F	140° F	175° F	210° F	250° F
16	400	85	45	85	45	30	15

* For lug style data consult factory

NOMINAL SIZE		GEAR OPERATED	NOMINAL SIZE		VACUUM SERVICE (INCHES OF MERCURY)
INCHES	mm		INCHES	mm	
16	400	79.40	16	400	-23.62

Cv Values

NOMINAL SIZE		Cv (at various opening degrees)		
INCHES	mm	30°	60°	90°
16	400	750	3760	8340