

CONDENSATE COMMANDER LITTLE BOY PUMP SPECIFICATION

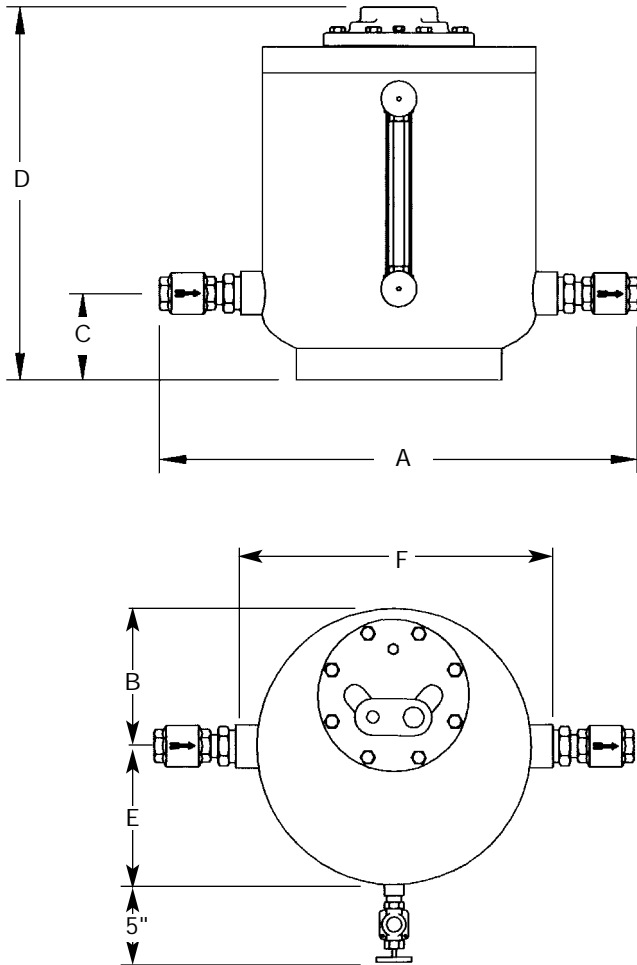

See Capacities on page 91

Connections:
1" x 1" to 1½" x 1½" NPT

Dimensions							
Size	Inches (mm)						Weight lbs(kg)
	A	B	C	D'	E*	F	
1" x 1"	26¾ (679)	8 (203)	5 (127)	21¼ (540)	9 (229)	17¾ (451)	145 (66)
1½" x 1½"	29½ (749)	8 (203)	5 (127)	21¼ (540)	9 (229)	17¾ (451)	155 (71)

*Add 5" for Water Gage.

'Allow additional 18" clearance for maintenance.

Pump shall be a pressure vessel drainer operated by steam, compressed air or other pressurized gas to 150 psig. Body shall be fabricated steel. Mechanism shall employ one spring operating in continuous compression. Spring shall be warranted for the life of the unit. When required, unit shall be equipped with an external cycle counter and sight glass.

MAXIMUM OPERATING CONDITIONS

PMO:

Max. Operating Pressure 150 psig (10.3 barg)

TMO:

Max. Operating Temperature 400°F (204°C)

PMA:

Max. Allowable Pressure 150 psig (10.3 barg)

TMA:

Max. Allowable Temperature 400°F (204°C)

MATERIALS OF CONSTRUCTION

Tank Weldment	Steel
Trip Mechanism w/Flange	DI/Stl/SS
Gasket	Non-asbestos
Bolt, Hex Head	Steel
Nameplate	Aluminum
Drive Screw	Steel
Water Level Gage	Bronze
Inlet Reducer	M. Iron
Inlet Nipple	Steel
Inlet Check Valve	Bronze/Stainless Steel
Outlet Reducer	M. Iron
Outlet Nipple	Steel
Outlet Check Valve	Bronze/Stainless Steel

OPERATING CHARACTERISTICS

Pump Discharge per Cycle: 4.2 - 5.1 Gal

Max. Instantaneous Discharge Rate:

60 GPM
(w/1½" outlet check)

Steam Consumption: ~3 lbs per 1000 lbs.
of liquid pumped

Air Consumption: ~100 SCF per 1000
lbs. of liquid pumped

Recommended Filling Head: 6"

Canadian Registration # 1353.92