

Series 49

Flanged Full Port Ball Valve

SHARPE[®]

Valves, Automation & Controls

Features

- Full port
- Class 150
- Locking device
- Blow-out proof stem
- ASME B16.10 face to face
- ASME B16.34 shell wall thickness, basic design & pressure testing
- ASME B16.5 flange dimensions
- API 598 pressure testing (optional)



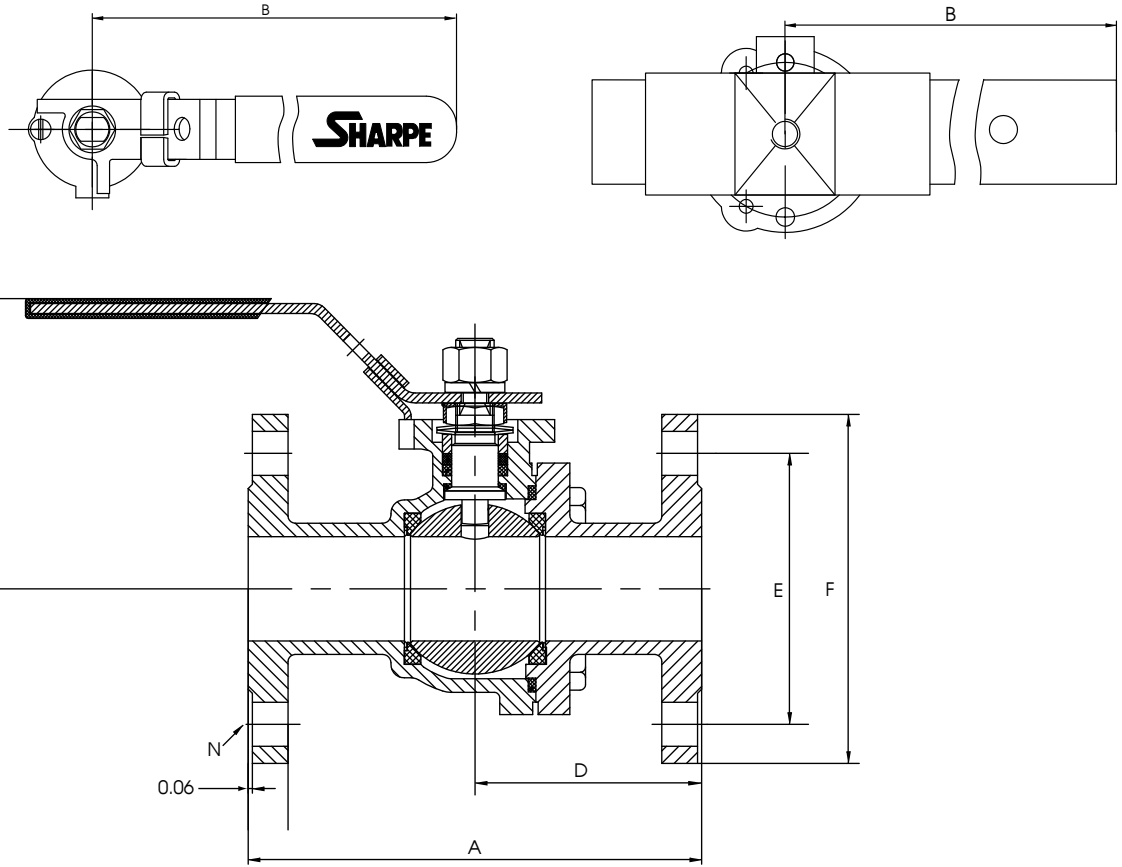

Size	A	B	C	D	E	F	N
1/2	4.25	4.65	3.00	2.13	2.38	3.50	4
3/4	4.62	4.65	3.35	2.32	2.75	3.85	4
1	5.00	6.18	3.75	2.50	3.13	4.25	4
1-1/2	6.50	9.13	4.50	3.25	3.56	5.00	4
2	7.00	9.13	4.80	3.50	4.75	6.00	4
2-1/2	7.50	13.13	6.70	3.74	5.50	7.00	4
3	8.00	13.12	7.00	4.00	6.00	7.48	4
4	9.00	13.12	7.70	4.51	7.50	9.01	8
6	15.50	25.50	9.45	7.76	9.50	10.98	8

6" - 8" Parts & Materials

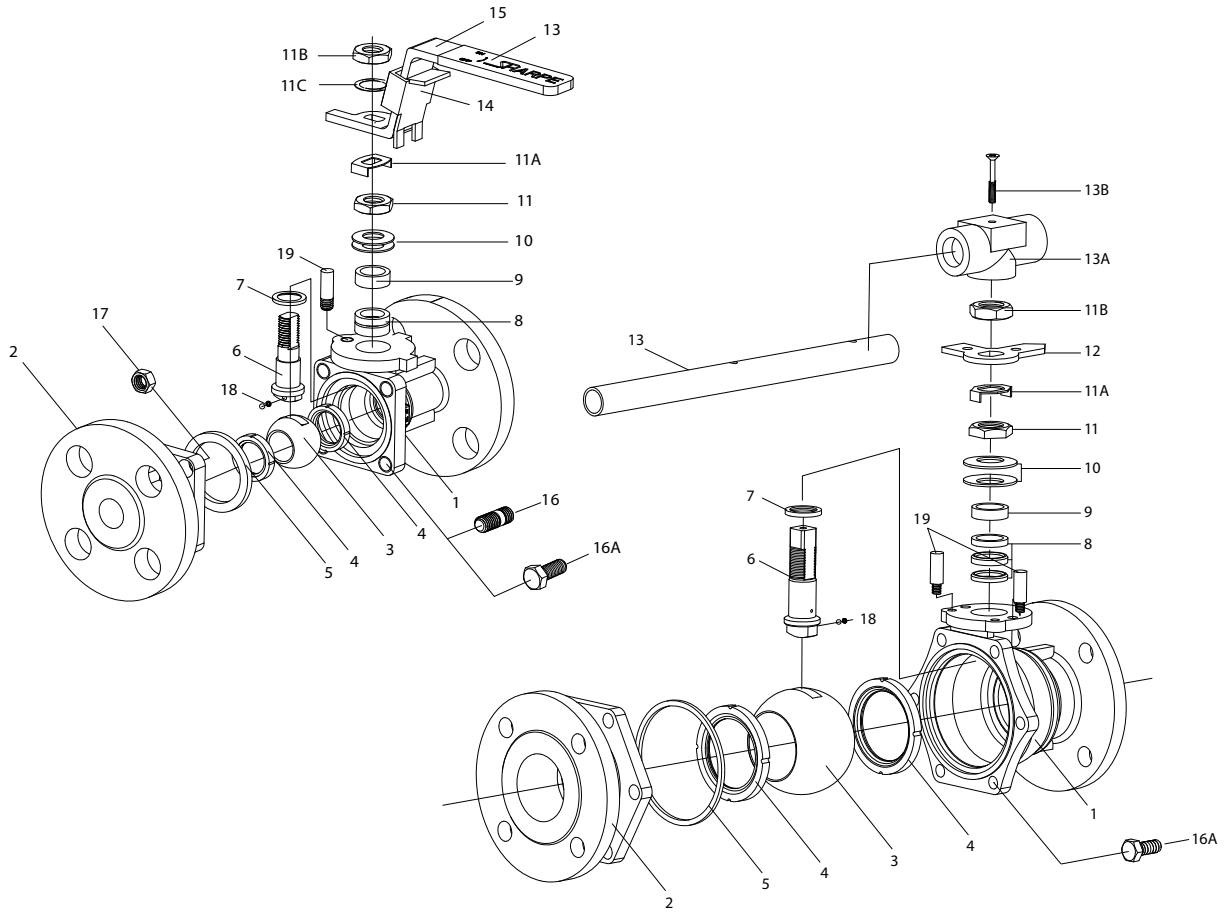

No.	Part Name	Qty	Material
1	Body	1	Carbon Steel, ASTM A216 WCB 316 Stainless Steel, ASTM A351 CF8M
2	End Connector	4	Carbon Steel, ASTM A216 WCB 316 Stainless Steel, ASTM A351 CF8M
3	Ball	1	316 Stainless Steel
4	Seat	2	Reinforced PTFE
5	Body Seal	1	PTFE
6	Stem	1	316 Stainless Steel
7	Thrust Bearing	1	316 Stainless Steel
8	Stem Packing (1/2"-2") (2-1/2" - 6")	2 3	PTFE PTFE
9	Gland Packing	1	304 Stainless Steel
10	Belleville Washer	2	304 Stainless Steel
11	Packing Nut	1	304 Stainless Steel
11A	Lock Tab	1	Stainless Steel
11B	Nut	1	304 Stainless Steel
11C	Nut Washer	1	304 Stainless Steel
12	Stopper	1	304 Stainless Steel
13	Handle	1	304 Stainless Steel (1/2" - 2")
13A	Wrench Block	1	304 Stainless Steel (2-1/2" - 6")
13B	Handle Bolt	1	304 Stainless Steel (2-1/2" - 6")
14	Locking Device (1/2" - 2")	1	304 Stainless Steel
15	Sleeve	1	PVC
16	Body Stud (1/2" - 1")	4	A193 ASTM A193, Gr. B8M (Stainless Steel)
16A	Body Bolt (1-1/2" - 6")	4/6/8	A193 ASTM A193, Gr. B8M (Stainless Steel) A193 ASTM A193, Gr. B7 (Carbon Steel)
17	Nut (1/2" - 1")	4	A194 ASTM A194, Gr. B8M (Stainless Steel)
18	Anti Static Device	2	316 Stainless Steel
19	Stop Pin (1/2" - 2") (2-1/2" - 6")	1 2	304 Stainless Steel 304 Stainless Steel

Class 150 Temperature / Pressure Rating

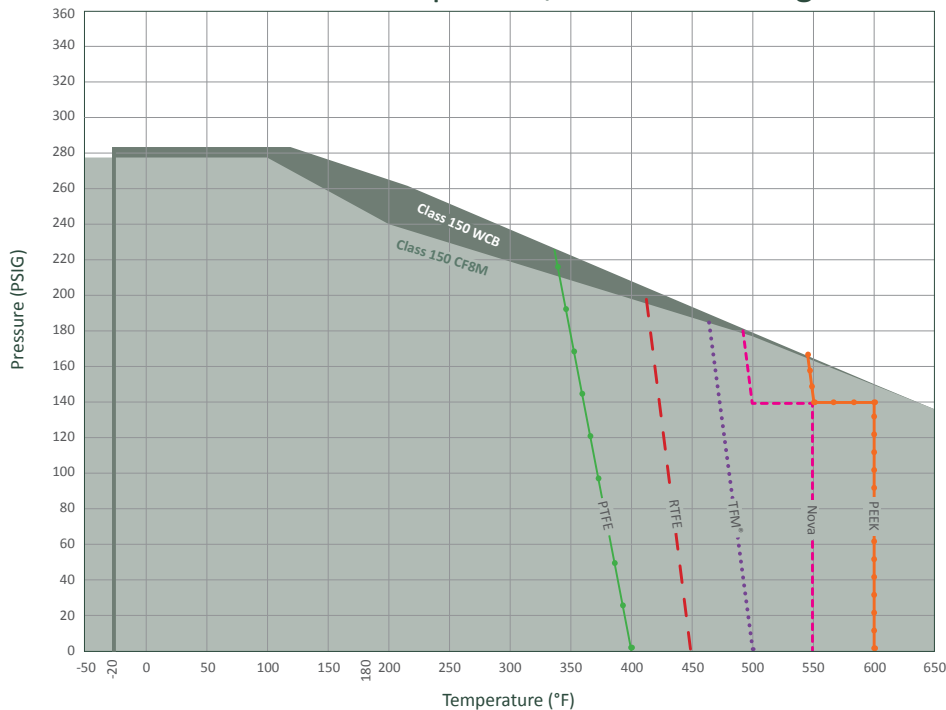

Size IN	CV	Port	Weight (lbs.)
1/2	26	0.59	3.50
3/4	50	0.78	4.50
1	94	1.00	6.50
1-1/2	260	1.50	12.00
2	480	2.00	18.00
2-1/2	750	2.55	29.00
3	1300	3.00	36.00
4	2300	4.00	54.00
6	5400	6.00	115.00

Ordering

Fig: 3/4 - 49 - 11 - 6 - R

Description: 3/4" - Series 49 - 150# - Stainless Steel - RTFE

Size	Series	Class	Alloy	Seats		
1/2	49	11	150#	R		
3/4					4 Carbon Steel	RTFE
1					6 Stainless Steel	
1-1/4						
1-1/2						
2						
2-1/2						
3						