

Series 50B7

Seal Weld Ball Valve

SHARPE[®]

Valves, Automation & Controls

Features

- 2000 CWP rating (1/4" - 2")
1500 CWP rating (2-1/2" & 3")
- 150 WSP with RTFE seats
250 WSP with Nova seats
- Shell tested to 8000 psi
- Seal weld construction
- ASTM A351 CF8M
- ASTM A216 WCB
- NACE MR-0175
- Full port
- Locking device
- Blow out proof stem



Dimensions

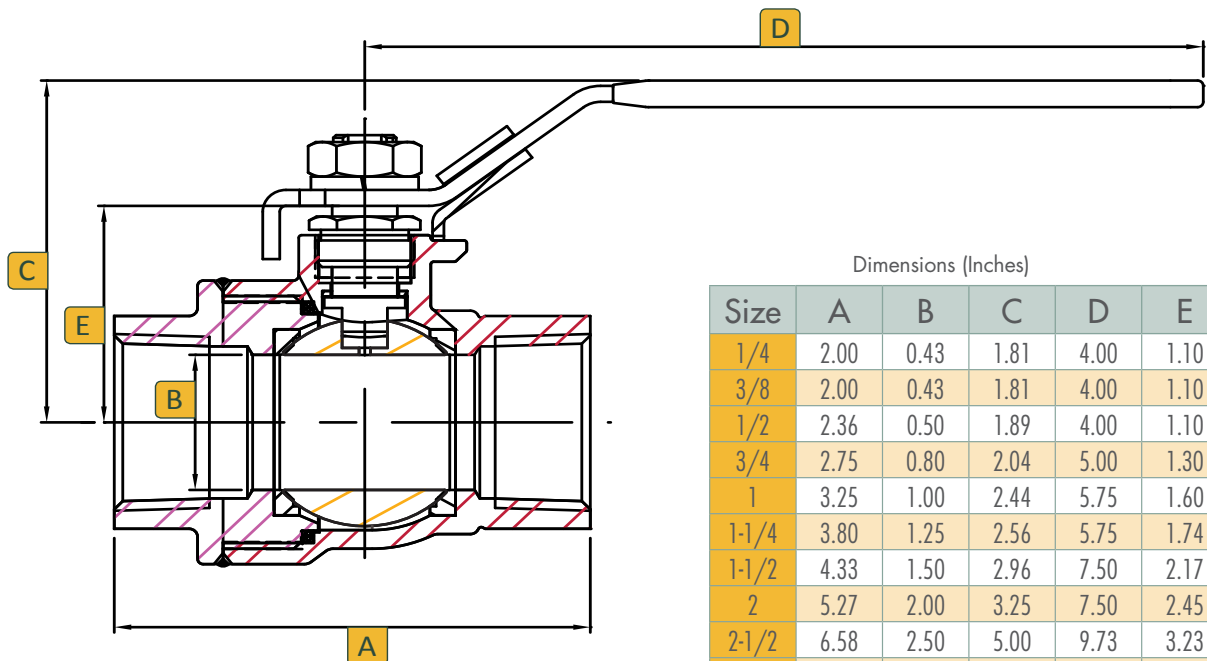

Dimensions (Inches)

Size	A	B	C	D	E
1/4	2.00	0.43	1.81	4.00	1.10
3/8	2.00	0.43	1.81	4.00	1.10
1/2	2.36	0.50	1.89	4.00	1.10
3/4	2.75	0.80	2.04	5.00	1.30
1	3.25	1.00	2.44	5.75	1.60
1-1/4	3.80	1.25	2.56	5.75	1.74
1-1/2	4.33	1.50	2.96	7.50	2.17
2	5.27	2.00	3.25	7.50	2.45
2-1/2	6.58	2.50	5.00	9.73	3.23
3	7.55	3.00	5.40	9.73	3.62

No.	Part Name	Qty	Material
1	Body	1	Carbon Steel ASTM A216 WCB or 316 Stainless Steel ASTM A351 CF8M
2	Ball	1	316 Stainless Steel ASTM A351 CF8M
3	Seat	2	RTFE / Nova
4	End Plug	1	Carbon Steel ASTM A216 WCB or 316 Stainless Steel ASTM A351 CF8M
5	Stem	1	316 Stainless Steel ASTM A351 CF8M
6	Stem Thrust Seal	1	RTFE / Nova
7	Stem Packing	1	PTFE / Grafoil
8	Packing Nut	1	304 Stainless Steel
9	Handle	1	304 Stainless Steel
10	Lock Washer	1	316 Stainless Steel ASTM A351 CF8M
11	Handle Nut	1	316 Stainless Steel ASTM A351 CF8M
12	Locking Device	1	304 Stainless Steel
13	Handle Sleeve	1	PVC
14	Body Seal	1	PTFE

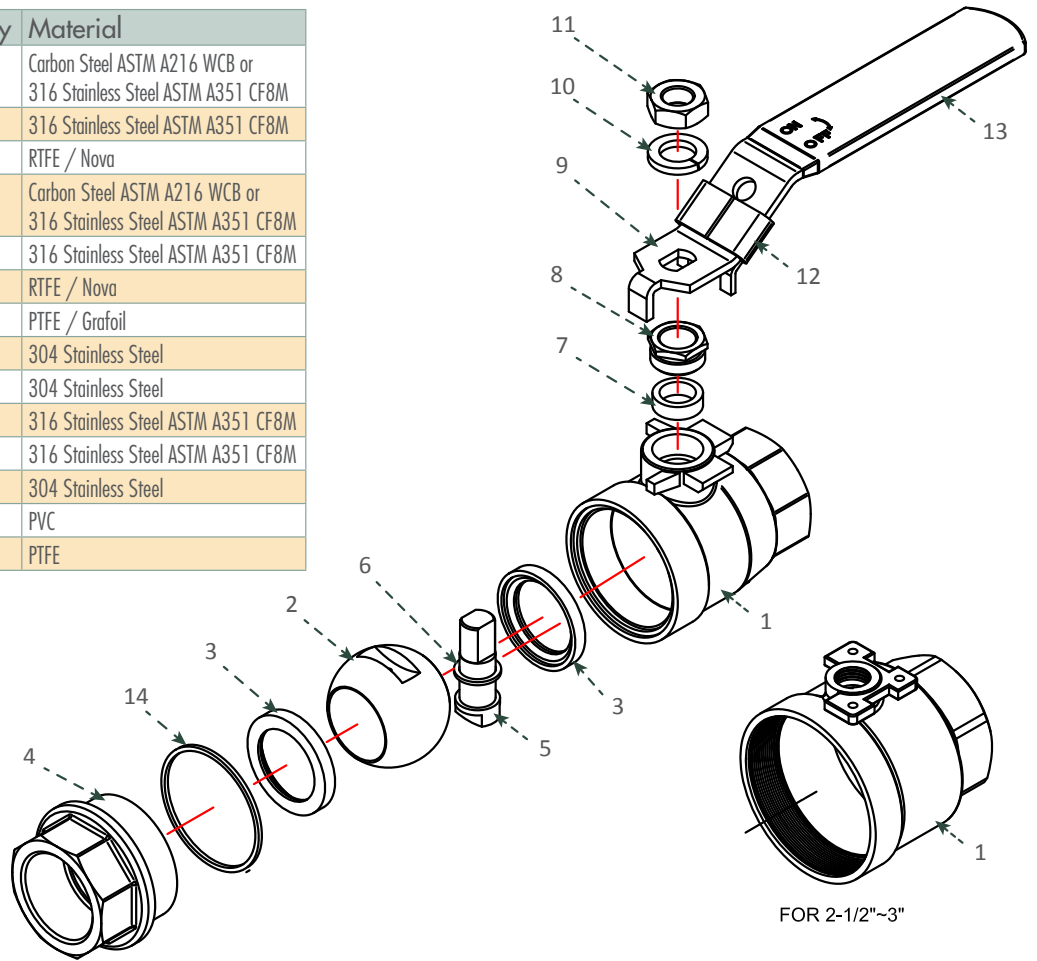

Technical Information

Size	CV	Weight LB
1/4	6	0.5
3/8	6	0.5
1/2	24	0.6
3/4	35	1.10
1	47	2.00
1-1/4	81	3.00
1-1/2	105	4.85
2	241	8.00
2-1/2	319	14.00
3	580	20.00

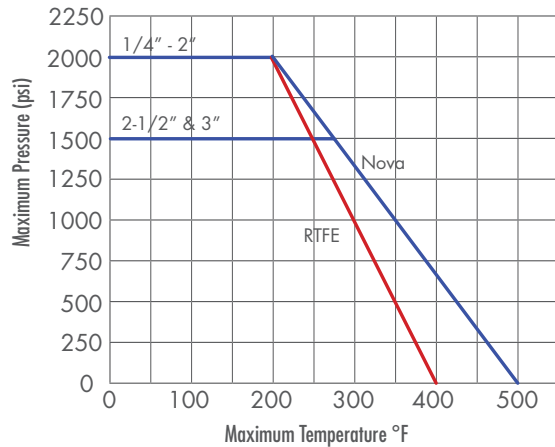

Ordering

Fig: 1/2 - 50B7 - 6 - N
Description: 1/2" - 50B7 - 316 Body - Nova Seat

Size	Series	Body	Seat
1/4	1-1/4	4 Carbon Steel	R RTFE
3/8	1-1/2	6 Stainless Steel	N Nova
1/2	2		
3/4	2-1/2		
1	3		

Due to continuous development of our product range, we reserve the right to change the dimensions and information for this product as required.