

# SHARPE<sup>®</sup> VALVES

S T A I N L E S S S T E E L



**THREADED  
GLOBE VALVE**

# Threaded Globe Valve

**ASTM-A351  
200 PSI WOG AT 350°F  
INSIDE SCREW AND SCREWED BONNET  
RISING STEM**

**Fig. No. 40276**

PART	NAME	MATERIAL
1	Hand Wheel Nut	304
2	Name Plate	Aluminum
3	Hand Wheel	Mild Steel
4	Packing Nut	CF8M
5	Packing Gland	304
6	Packing	Teflon
7	Stem	316
8	Bonnet	CF8M
9	Body	CF8M
10	Disc	316

Hydrostatic Shell Test	300 PSI
Hydrostatic Seat Test	220 PSI

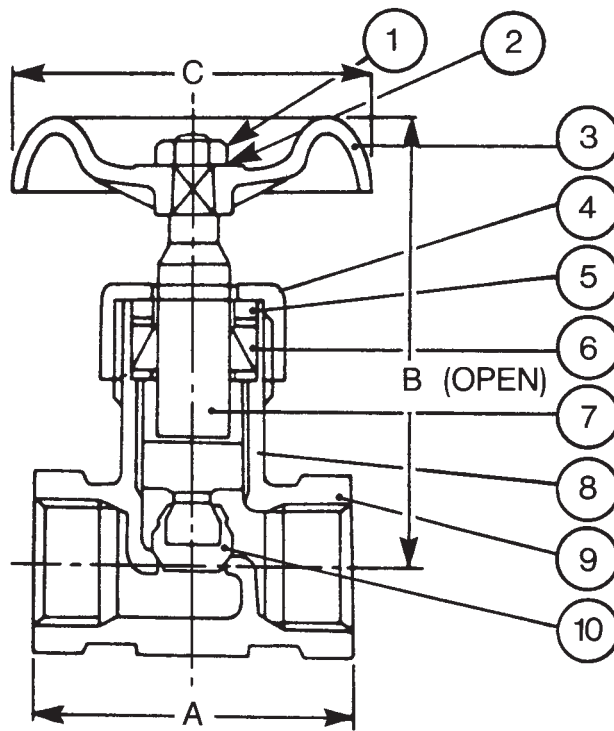

## DIMENSIONS IN INCHES

Size	1/2	3/4	1	1-1/4	1-1/2	2
A	2.56	3.15	3.54	4.13	4.72	5.51
B (Open)	3.54	3.74	4.53	5.12	5.70	6.10
C	2.36	2.76	3.15	3.15	3.54	3.94
Weight (lbs)	0.86	1.34	1.92	2.73	3.96	5.62

**SHARPE® VALVES**  
A Division of Smith-Cooper International, LLC

**Toll Free: 1-877-7SHARPE**  
**(877) 774-2773**  
Fax: (708) 562-9250  
Email: [info@sharpevalves.com](mailto:info@sharpevalves.com)  
[www.sharpevalves.com](http://www.sharpevalves.com)  
1260 Garnet Drive  
Northlake, Illinois 60164 U.S.A.