

600WT SERIES CAST STEEL AND STAINLESS STEEL DOUBLE DOOR CHECK VALVES

PRESSURES TO 1480 PSIG (101.9 BARG)
TEMPERATURES TO 600°F (316°C)

- ASME Class 600 rated check valves
- Wafer body style fits between FF or RF flanges
- Upper and lower SS thrust washers
- Resilient Buna-N , Viton and metal seats
- Seat design lifts then swings discs to minimize seat wear
- Shock bumpers minimize stresses in hinge pins
- Independent springs optimizes valve plate closing rates while minimizing spring stress
- Dual ratings 2"-3" 150#, 300# and 600#.

APPLICATIONS

- Liquid and Air Service
- Process Industry
- Power Industry
- Chemical Industry
- Oil & Gas
- Pulp & Paper
- Metal & Mining
- Water & Waste

PRESSURE/TEMPERATURE CHART
ASME B16.34

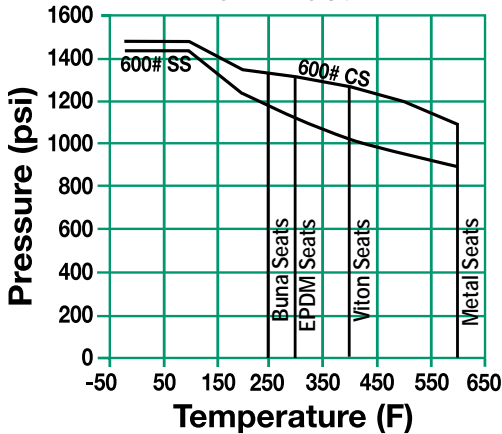

MODELS

- 600WTCT – Cast Steel Body, Stainless Steel Disc, Buna Seat
- 600WTTT – Stainless Steel Body, Stainless Steel Disc, Metal or Viton Seats

OPTIONS (Consult Factory)

- EPDM Seats
- Other Spring Material

APPLICABLE CODES

- ASME B16.34 ratings
- API 594
- API 598

Canadian Registration - OC10274.5C

600WT Series Ordering Code

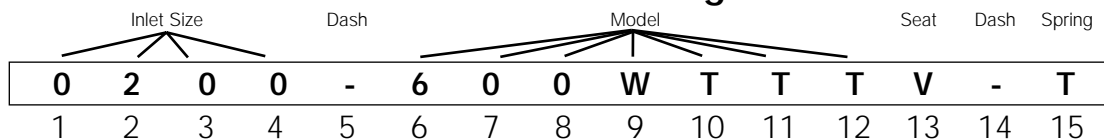

Inlet Size* - Position 1 - 4 0200 - 2" 0250 - 2½" 0300 - 3"
Dash - Position 5
Model - Position 6 - 12 300WTCT - CS Body 300WTTT - SS Body

Seat** - Position 13 B - Buna-N (CS Body only) M - Metal (SS Body only) V - Viton (SS Body only)
Dash - Position 14
Spring - Position 15 T - SS

* For sizes 2", 2½", 3"
600WT check valves fit between all ANSI 150#, 300# & 600# class flanges.

** 600WTCT - Buna-N seat only,
600WTTT - Viton or Metal seat

600WT SERIES CAST STEEL AND STAINLESS STEEL DOUBLE DOOR CHECK VALVES

SPECIFICATION

Check Valve shall be dual disc design with Cast Steel or Stainless Steel Body wafer body style designed to ASME B16.34 and API 594. The check valve shall have an integral cast bumper and Buna-N or Viton resilient seats with SS discs. The check valve shall be ASME Class 600 rated. The spring shall be 316SS. The seat design shall lift then swing discs to minimize seat wear. The check valve shall be SSI 300WT Series.

MATERIALS OF CONSTRUCTION

Part	Carbon Steel	Stainless Steel
Body	A216-WCB	A351-CF8M
Discs	A351-CF8M	A351-CF8M
Seat	Buna-N	Viton or Metal
Spring	304 SS	304 SS

CRACKING PRESSURE

Horizontal Mounting - .3psid

Vertical Mounting - .75 to 1.25 psid

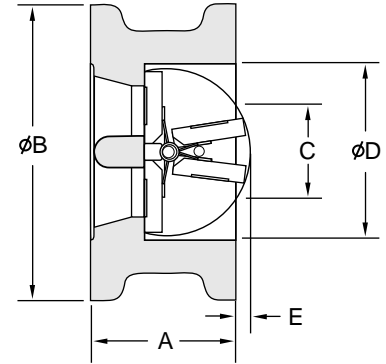
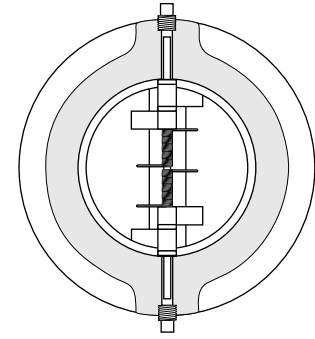

DOUBLE DOOR
CHECK VALVES

Connections: 2" to 3"
Wafer Flanged

Seats:
CS Body - 2" to 3" Buna-N
SS Body - 2" to 3" Viton or Metal

DIMENSIONS inches (mm) AND WEIGHTS pounds (kg)

Size		A ¹	B*	C ²	D	E	STUD SELECTION			Weight
							Qty.	Dia.	Length	
2 ³ (50)	150#	2 1/8 (60)	4 1/8 (105)	—	2 1/8 (60)	—	4	5/8 (15.9)	6 (152)	6 (2.7)
	300#/ 600#	2 1/8 (60)	4 3/8 (111)	—	2 1/8 (60)	—	8	5/8 (15.9)	6 1/2 (175)	6 (2.7)
2 1/2 ³ (65)	150#	2 1/8 (67)	4 1/8 (124)	2 (51)	3 (77)	1/4 (6)	4	5/8 (15.9)	6 1/2 (159)	10 (4.5)
	300#/ 600#	2 1/8 (67)	5 1/8 (130)	2 (51)	3 (77)	1/4 (6)	8	3/4 (19)	7 1/2 (190)	10 (4.5)
3 ³ (80)	150#	2 1/8 (73)	5 1/8 (137)	2 (51)	3 1/2 (89)	1/4 (6)	4	5/8 (15.9)	7 (178)	13 (5.9)
	300#/ 600#	2 1/8 (73)	5 1/8 (149)	2 (51)	3 1/2 (89)	1/4 (6)	8	3/4 (19)	8 1/2 (207)	13 (5.9)

1. Dimensions in accordance with API 594.
2. Minimum diameter of companion flanges.
3. 300WT and 600WT are interchangeable, use 600WT for both applications.

Dimensions are subject to change. Consult factory for certified drawings when required.

* Add the "B" dimension and the diameter of the stud to achieve the ANSI B16.5 bolt hole circle diameter.

600WT SERIES DOUBLE DOOR CHECK VALVES

CAST STEEL AND STAINLESS STEEL

PRESSURE DROP - LIQUIDS

Sizes 2" - 3"

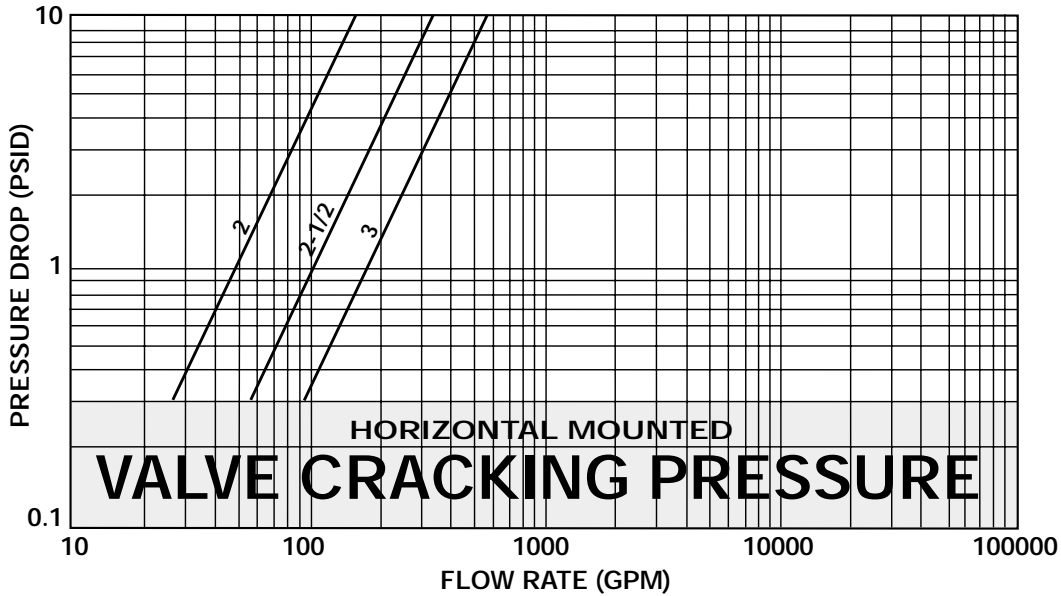

- (1) Pressure drop curves are based on water flow.
- (2) Valve cracking pressure is equal to or less than 0.3 psid when mounted horizontally.
- (3) Valve cracking pressure increases to between 0.75 and 1.25 psid when installed vertically with flow upwards.

PRESSURE DROP - AIR

Sizes 2" - 3"

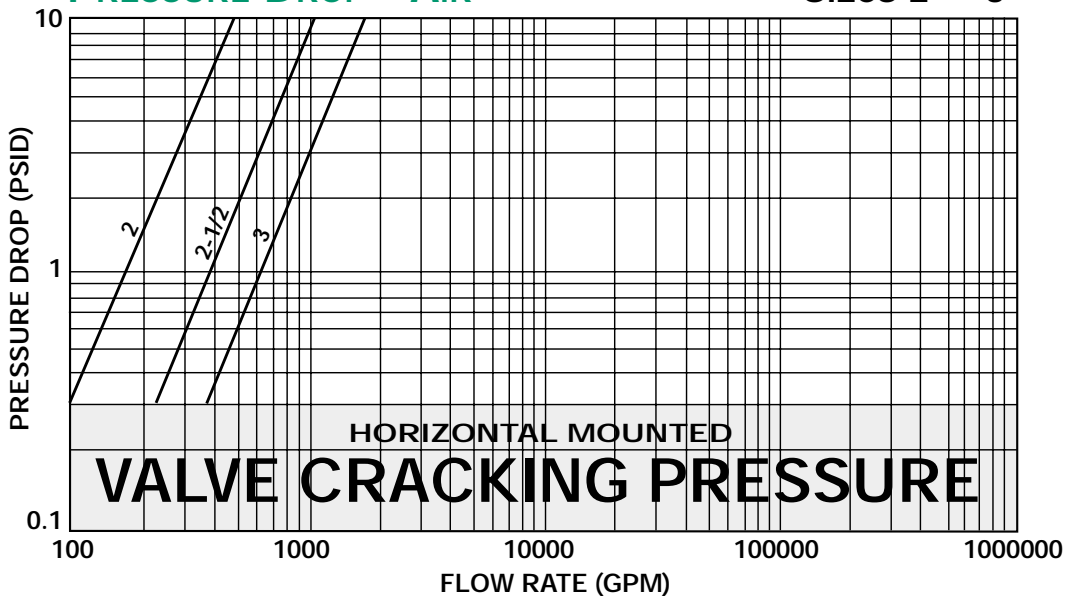

- (1) Pressure drop curves are based on air flow at 60 OF and 1 ATM pressure.
- (2) Valve cracking pressure is equal to or less than 0.3 psid when mounted horizontally.
- (3) Valve cracking pressure increases to between 0.75 and 1.25 psid when installed vertically with flow upwards.

Installation Note:

- 1) For correct installation and maintenance please see our I&M manual.
- 2) Horizontal installation – Disc pin must be installed in vertical position.
- 3) Vertical installation (downward flow) – Consult factory.

C_v VALUES (US-GPM @ 1 PSID)

Valve Size (inches)	2	2½	3
C _v	48	90	171

DOUBLE DOOR
CHECK VALVES

