



FIGURE 10 SERIES SAFETY VALVE

# FIGURE 10 SERIES

SIZES 3/4" – 3"

PRESSURES to 15 PSIG at 250°F

- Meets ASME Section IV Code for Steam Service
- "HV" National Board Certified
- Low Cost
- High Capacity
- Dependable
- Tight Shutoff
- Sharp Popping and Closing Action
- High Degree of Repeatability
- Unitized Body

## MODELS

- 0010 - Cast Iron Body, Bronze Seats

## APPLICATION DATA

- Industrial Low Pressure Steam Heating Boilers
- Commercial Low Pressure Steam Heating Boilers

## VALVE RATINGS

Model	Pressure PSIG (bar)	Temperature °F (°C)
All	5 to 15 (.3 to 1)	-20 to 250 (-29 to 121)

## APPLICABLE CODES

- ASME Section IV "HV" for Low Pressure Steam (when set @ 15 PSI)
- Canadian Registration #0G0591.9C

## CODE SELECTION CHART

Model				Orifice	Inlet Size	Connections	Set Pressure			
0	0	1	0	Z	H	A	-	0	1	5
1	2	3	4	5	6	7	8	9	10	

<b>Model -</b> Position 1, 2, 3 & 4 0010 = Cast Iron Body, Bronze Seats
<b>Orifice -</b> Position 5 Z

<b>Inlet Size -</b> Position 6 D = 3/4 E = 1 F = 1 1/4 G = 1 1/2 H = 2 J = 2 1/2 K = 3
--

<b>Connections -</b> Position 7 A = MPT x FPT
<b>Set Pressure -</b> Position 8, 9 & 10 — — — = Actual Setting

# FIGURE 10 SERIES

## SPECIFICATION

The valve shall meet the ASME Section IV Code for low pressure steam service. It shall be "HV" National Board Certified. The valve inlet and outlet shall be one integral casting assuring proper alignment of disc, seat and spindle for smooth action. The valve shall maintain a high degree of repeatability. The valve shall be top guided by a disc guide fitted into the body. The valve shall have an open lever assembly. The valve shall have a non-adjustable blowdown.

## MATERIALS OF CONSTRUCTION

Ref	Part Name	Material
1	Pull Ring	SST
3	Compression Screw	Stl. plated CI ASTM A108/A126
4	Seal Wire	SST
5	Seal	Lead
6	Lock Screw	Brass ASTM B16
7	Drive Screw	SST
8	Nameplate	SST
9	Wave Washer	Plated Steel
10	Spring	Plated Steel
11	Disc Guide	Brass/Bronze ASTM B135/B505
12	Spindle Pin	Plated Steel
13	Spring Washer	Plated Steel
14	Spindle	Steel ASTM A108
15	Disc	Brass/Bronze ASTM B16/B62
16	Seat	Brass/Bronze ASTM B16/B505
17	Body	Cast Iron ASTM A126
18	Sealant	Sealant

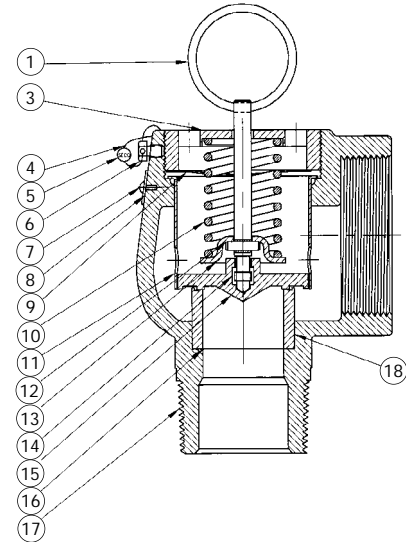
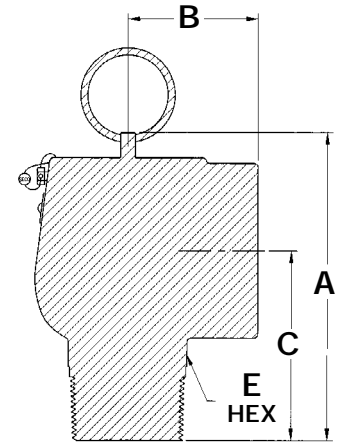

## DIMENSIONS inches (mm) AND WEIGHTS pounds (kg)

Model	Inlet	Orifice	Outlet	A*	B	C	E Hex	Weight
0010ZDA	¾ (20)	Z	1 (25)	3⅞ (76)	1½ (38)	2⅞ (56)	1¼ (32)	1 (.4)
0010ZEA	1 (25)	Z	1¼ (32)	4 (95)	2 (51)	2⅞ (67)	1½ (38)	2 (.9)
0010ZFA	1¼ (32)	Z	1½ (40)	5 (108)	2½ (54)	3 (76)	1⅞ (48)	3 (1.4)
0010ZGA	1½ (40)	Z	2 (50)	5⅞ (117)	2⅞ (56)	3⅞ (81)	2 (51)	4 (1.8)
0010ZHA	2 (50)	Z	2½ (65)	6⅞ (156)	2⅞ (73)	4 (102)	3 (76)	8 (3.6)
0010ZJA	2½ (65)	Z	2½ (65)	8⅞ (194)	3⅞ (95)	4⅞ (111)	3¼ (83)	14 (6.3)
0010ZKA	3 (80)	Z	3 (80)	9⅞ (229)	3⅞ (98)	5⅞ (130)	4 (102)	22 (10)

\* Add 1/4" to "A" dimension to allow for lift.

# SATURATED STEAM CAPACITY CHART—MODEL 0010

ASME Section IV "HV" 90% rated at 33.3% Overpressure\*\* LBS/HR (KGS/HR)

### LBS/HR

Set Pressure PSIG	Valve & Orifice Area, in <sup>2</sup>						
	¾ Z 1 0.276	1 Z 1¼ 0.49	1¼ Z 1½ 0.765	1½ Z 2 1.107	2 Z 2½ 1.961	2½ Z 2¾ 3.063	3 Z 3 4.43
5*	243	431	673	974	1725	2694	3896
10*	318	565	883	1277	2263	3534	5112
15	394	700	1093	1581	2801	4375	6327

\* Pressure settings below 15 PSIG (1.034 barg) are non code.

\*\* Pressure settings below 15 PSIG (1 barg) are at 10% overpressure.

### KGS/HR

Set Pressure Barg	Valve & Orifice Area cm <sup>2</sup>						
	20 Z 25	25 Z 32	32 Z 40	40 Z 50	50 Z 65	65 Z 65	80 Z 80
1.78	1.78	3.16	4.94	7.14	12.65	19.76	25.58
0.4*	255	452	706	1022	1811	2828	4091
0.7*	321	569	889	1286	2279	3559	5148

Consult Factory for capacities below 5 PSIG