



**FIGURE 50 SERIES SAFETY VALVE**

# FIGURE 50 SERIES

SIZES 2"

PRESSURES to 30 PSIG at 225°F

- Air, Gas, Vapors and Powdered Solids
- High Capacity
- Tamper Proof Spring Setting
- Weatherproof
- Spring Chamber Isolated from Process Fluid
- Soft Seat Seal
- Bronze or Aluminum Body

## MODELS

- 0050 - Bronze Body, Viton Soft Seat
- 0051 - Pull Ring on 0050
- 0052 - Aluminum Body, Viton Soft Seat
- 0053 - Pull Ring on 0052

## APPLICATION DATA

- Bulk Hauling Truck Tank Trailers
- Bulk Hauling Railroad Tank Cars
- Storage Vessels for Powdered Solids (flour, cement, etc.)

## VALVE RATINGS

Model	Pressure PSIG (bar)	Temperature °F (°C)
All	10 to 30 (.7 to 2.1)	-20 to 225 (-29 to 107)

## APPLICABLE CODES

- Canadian Registration #0G0591.9C

## CODE SELECTION CHART

Model				Orifice	Inlet Size	Connec- tions	Set Pressure			
0	0	5	2	Z	H	Z	-	0	1	5
1	2	3	4	5	6	7	8	9	10	

**Model -**  
 Position 1, 2, 3 & 4  
 0050 = Bronze Body, Viton Soft Seat  
 0051 = Pull Ring on 0050  
 0052 = Aluminum Body, Viton Soft Seat  
 0053 = Pull Ring on 0052

**Orifice -**  
 Position 5  
 Z  
**Inlet Size -**  
 Position 6  
 H = 2

**Connections -**  
 Position 7  
 Z  
**Set Pressure -**  
 Position 8, 9 & 10  
 \_\_\_ = Actual Setting  
 LAS - Loosely Assembled†

†Spence Certified Assemblers Only

# FIGURE 50 SERIES

## SPECIFICATION

The valve shall meet the ASME Section VIII Code for air services. It shall be "UV" National Board Certified. The valve setting shall be tamper resistant. The valve shall be weatherproof and the diaphragm shall completely seal the spring chamber from the process fluid. The valve shall have an O-ring seat seal for tight shutoff.

## MATERIALS OF CONSTRUCTION

Ref	Part Name	Material
1	Pull Ring	SST
3	Spindle (0051/0053)	Steel ASTM A108. 12L14
4A	Cover	Bronze ASTM B62
4B	Cover	Aluminum ASTM B 26, A03560, T6
5	Spring	Steel ASTM A228, Plated
6	Disc Nut	Steel, Plated
7	Retaining Ring	Steel, Plated
8	Weather Seal	Viton
9	Wave Spring	Steel, Plated
10	Washer	Steel, Plated
11	Diaphragm	Nylon Reinforced
12	Disc Washer	Plated Steel
13	Disc	ASTM B16, C36000, H02
14	Seat Seal	Viton
15A	Body	Bronze ASME SB62
15B	Body	Aluminum ASTM B26, A03560, T6
16	Fender Washer	Steel, Plated
17	Nameplate	SST
18	Drive Screw	SST

Lead seal plus SS wire not shown

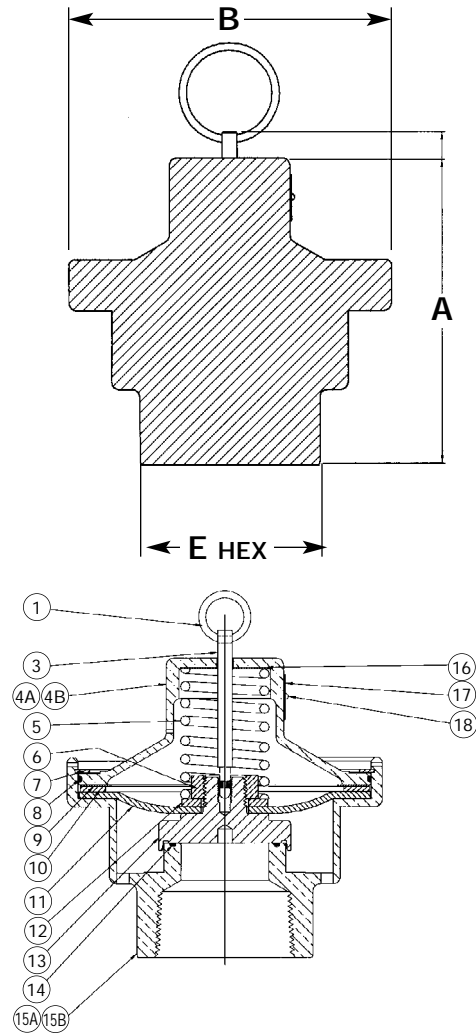

## DIMENSIONS\* inches (mm) AND WEIGHTS pounds (kg)

Model	Inlet	Orifice	Outlet	A	B	E	Weight
0050ZHZ	2 (50)	Z	Atmosphere	5 <sup>3</sup> / <sub>2</sub> (129)	5 <sup>3</sup> / <sub>8</sub> (136)	3 (76)	7 (3.2)
0051ZHZ	2 (50)	Z	Atmosphere	6 (152)	5 <sup>3</sup> / <sub>8</sub> (136)	3 (76)	7 (3.2)
0052ZHZ	2 (50)	Z	Atmosphere	5 <sup>3</sup> / <sub>2</sub> (129)	5 <sup>3</sup> / <sub>8</sub> (136)	3 (76)	3 (1.4)
0053ZHZ	2 (50)	Z	Atmosphere	6 (152)	5 <sup>3</sup> / <sub>8</sub> (136)	3 (76)	3 (1.4)

# AIR CAPACITY CHART – MODELS 0050, 0051, 0052, 0053

ASME Section VIII "UV" 90% rated at 10% Slope SCFM (NM<sup>3</sup>/HR)

### SCFM

Set Pressure PSIG	Orifice Area, in <sup>2</sup>
	2.011
10*	637
15	752
20	867
25	982
30	1097
1.0	25.3

### NM<sup>3</sup>/HR

Set Pressure Barg	Orifice Area cm <sup>2</sup>
	12.97
0.6*	1082
0.8*	1278
1.0*	1473
1.2	1669
0.1	43.0

\* Pressure settings below 15 PSIG (1.034 barg) are non code.