



Titan Flow Control, Inc.

Your pipeline to the future!

Series BF 75

Wafer Style > Cast Iron

Series BF 76

Lug Style > Ductile Iron

Designed in accordance with:
MSS-SP-67 & API 609

Color Coded:
Orange Body is EPDM Seat
Blue Body is Buna-N Seat

Size Range: 2" ~ 48"

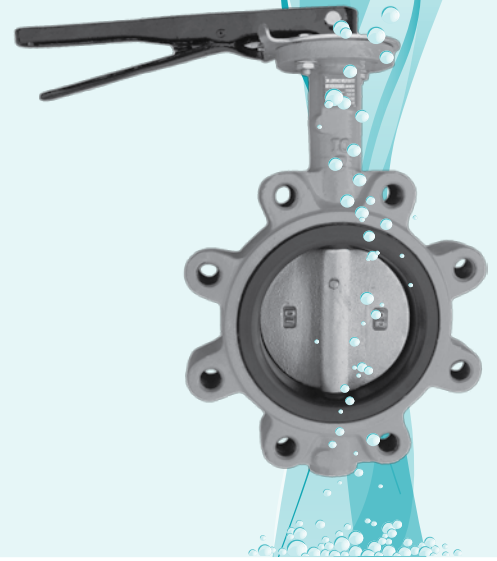

Resilient Seated Butterfly Valves Wafer Type Cast Iron > Lug Type Ductile Iron

Design Features

> Universal Mounting Flange

The cast-in actuator flange is universally designed in accordance with ISO 5211 standard dimensions. The mounting flange can accommodate all types of operators such as: 10-position handle kits, gear operators, electric actuators, and pneumatic actuators. For actuators, Titan FCI may provide both direct mount and bracket mount designs. Please contact Titan FCI about your specific automation requirements.

> Extended Neck

The extended neck provides clearance for 2" of piping insulation. Also, it elevates mounted actuators for easier access. Stem extensions are available to further elevate the operating location of the valve. Please contact factory for additional information.

> Installation Locating Holes

Model BF 75-CI is a wafer style, one-piece body construction with four cast-in alignment holes that aid in centering the valve body to existing ASME B16.10 flanges during installation. Model BF 76-DI is lug style with tapped lugs in accordance with ASME B16.42 Class 150 specifications. Both Lug and Wafer Style valves are compatible with ANSI 125/150 bolting patterns.

> One-Piece Through Stem Design

The one-piece, double 'D' stem design offers exceptionally high strength, stability, dependability and accurate disc positioning. Sizes 2" through 6" are equipped with double 'D' style stems. Sizes 8" and larger utilize a round stem design with key. Valves 30" and up use a two piece stem design.

> Applicable Standards

Butterfly valves are designed in accordance with ASME/ANSI Class 125/150 lb class flanges as well as MSS-SP-25, MSS-SP-67, and API 609 specifications. All valves are 100% hydrostatically tested in both directions in compliance with API 598 to ensure a bubble-tight seal.



> 290 Corporate Drive > Lumberton, NC 28358
> PO Box 7408
> 910-735-0000 T > 910-738-3848 F

www.titanfci.com

titan@titanfci.com

BF 75 & BF 76 > Sizes: 2" ~ 8"

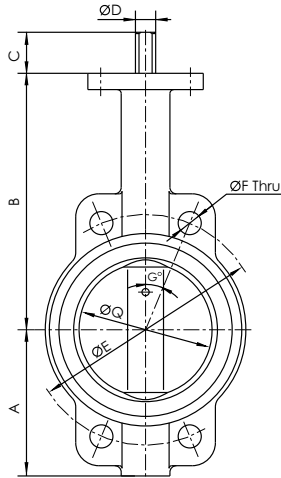

Front View
BF 75 > Wafer Style

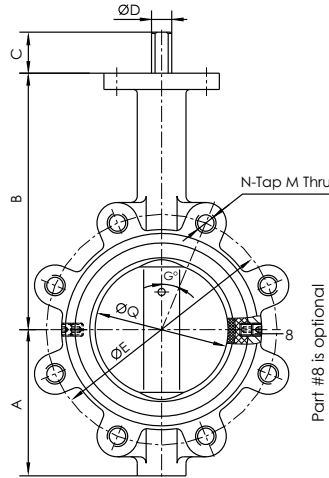

Front View
BF 76 > Lug Style

Part #8 is optional

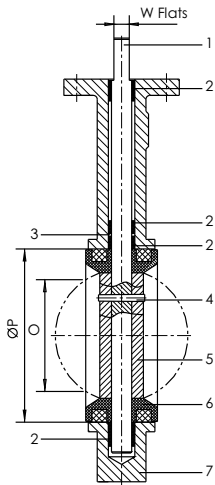

Side View
Wafer & Lug Style

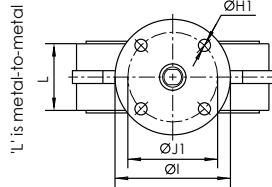

Top View 2" ~ 6"
Wafer & Lug Style

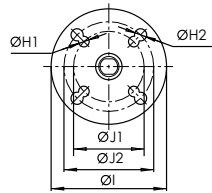

Top View 8" Only
Wafer & Lug Style

BILL OF MATERIALS ⁽¹⁾

No.	PART	WAFER STYLE	LUG STYLE
1	Stem	T-410 SS	T-410 SS
2	Bushing	PTFE	PTFE
3	O-Ring	EPDM ⁽²⁾ or Buna-N	EPDM ⁽²⁾ or Buna-N
4	Pin ⁽³⁾	T-410 SS	T-410 SS
5	Disc	Bronze or Nickel Plated	DI or CF8M T-316 SS
6	Seat ⁽⁴⁾	EPDM ⁽²⁾ or Buna-N	EPDM ⁽²⁾ or Buna-N
7	Body	Cast Iron	Ductile Iron
8	Set Screw ⁽⁵⁾	Carbon Steel	Carbon Steel

- BOM represents standard materials. Equivalent or better materials may be substituted at the manufacturer's discretion.
- EPDM is sulfur cured.
- Sizes 8" through 24" valves have two pins (Part number four).
- Seat is phenolic backed cartridge.
- Part number eight (Set Screw) is optional and only applies to Lug Style valves when customer specifies valve for dead-end service. Part number eight is not included on standard valves.

TECHNICAL NOTES

Valves are designed to comply with MSS SP-67 Type II

Valves are tested to comply with API 598

Bolting pattern conforms to Cast Iron ASME B16.1 Class 125 and Ductile Iron ASME B16.42 Class150 ⁽¹⁾

Top flange drilling conform to ISO 5211

Maximum working pressure is 200 PSI for sizes 2" through 12"

Sizes 2" through 6" have double 'D' style stems

Sizes 8" and larger have round style stems

Valves can be made silicone free upon request

Not recommended for steam service (consult factory)

- Bolting pattern for Cast Iron ANSI Class 125 and Ductile Iron Class 150 are identical. Pressure ratings are not identical. Valves 2" ~ 12" have a maximum working pressure of 200 PSI and 14" ~ 48" have a maximum working pressure of 150 PSI. Pressure ratings are lower for dead-end service.

WEIGHT DATA ⁽¹⁾

SIZE	2 lb kg	2.5 lb kg	3 lb kg	4 lb kg	5 lb kg	6 lb kg	8 lb kg
Wafer Style	7.5 3.4	8.5 3.9	9.2 4.2	12.7 5.8	14.5 6.6	17.5 7.9	42.5 19.3
Lug Style	8.5 3.9	11.5 5.2	11.0 5.0	16.0 7.3	20.0 9.1	26.5 12.0	49.5 22.5

DIMENSIONAL DATA ⁽¹⁾

SIZE in mm	A in mm	B in mm	C in mm	D in mm	E in mm	F in mm	G Deg.	H1 in mm	H2 in mm	I in mm	J1 in mm	J2 in mm	L in mm	M ⁽²⁾ UNC	N ⁽²⁾ Qty	O ⁽³⁾ in mm	P in mm	Q in mm	W in mm
2	2.99	6.38	1.26	0.50	4.75	0.69	45	0.37	n/a	3.54	2.76	n/a	1.65	5/8 - 11	4	1.26	3.01	2.01	0.37
50	76	162	32	12.7	120.65	17.50	---	9.5	n/a	90	70	n/a	42	---	4	32	76.4	51	9.5
2 1/2	3.50	6.89	1.26	0.50	5.50	0.69	45	0.37	n/a	3.54	2.76	n/a	1.77	5/8 - 11	4	1.85	3.51	2.47	0.37
65	89	175	32	12.7	139.7	17.50	---	9.5	n/a	90	70	n/a	45	---	4	47	89.1	62.8	9.5
3	3.74	7.13	1.26	0.50	6.00	0.69	45	0.37	n/a	3.54	2.76	n/a	1.77	5/8 - 11	4	2.56	4.09	3.04	0.37
80	95	181	32	12.7	152.4	17.50	---	9.5	n/a	90	70	n/a	45	---	4	65	104	77.3	9.5
4	4.49	7.87	1.26	0.63	7.50	0.69	22.5	0.37	n/a	3.54	2.76	n/a	2.05	5/8 - 11	8	3.54	5.32	4.04	0.44
100	114	200	32	15.9	190.5	17.50	---	9.5	n/a	90	70	n/a	52	---	8	90	135.1	102.5	11.1
5	5.00	8.39	1.26	0.75	8.50	0.81	22.5	.037	n/a	3.54	2.76	n/a	2.13	3/4 - 10	8	4.37	6.26	4.80	0.50
125	127	213	32	19.1	215.9	20.60	---	9.5	n/a	90	70	n/a	54	---	8	111	159.1	121.8	12.7
6	5.47	8.86	1.26	0.75	9.50	0.81	22.5	0.37	n/a	3.54	2.76	n/a	2.20	3/4 - 10	8	5.71	7.42	6.00	0.50
150	139	225	32	19.1	241.3	20.60	---	9.5	n/a	90	70	n/a	56	---	8	145	188.5	152.4	12.7
8	6.97	10.24	1.75	0.87	11.75	0.81	22.5	0.45	0.55	5.91	4.02	4.92	2.36	3/4 - 10	8	7.60	9.38	7.91	0.63
200	177	260	44	22.2	298.45	20.60	---	11.5	14	150	102	125	60	---	8	193	238.3	200.9	15.9

1. Dimensions and weights are for reference only. When required, request certified drawings. Weights for 2" ~ 8" include lever.

2. Dimensions 'M' and 'N' only are applicable to Lug Style valves. Dimensions 'M' is Unified Inch Screw Thread, coarse pitch series (UNC) per ANSI B1.1. 'N' is the number of bolt holes.

3. Dimension 'O' is disc chordal dimension at valve face.



BF 75 & BF 76 > Sizes: 10" ~ 24"

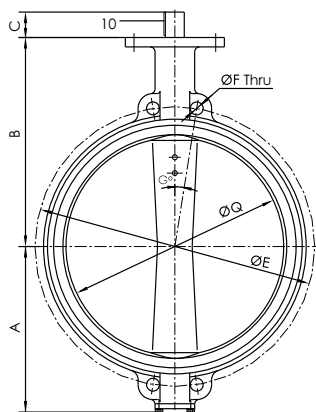

Front View
BF 75 > Wafer Style

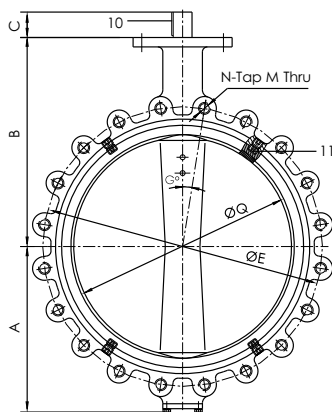

Front View
BF 76 > Lug Style

Part # 11 is optional

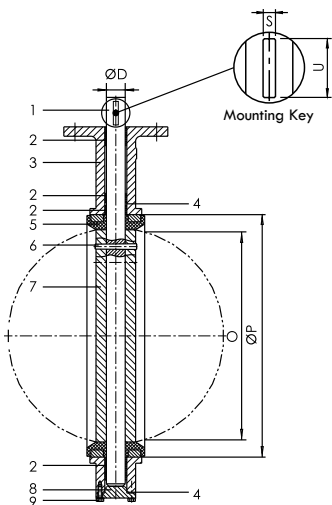

Side View
Wafer & Lug Style

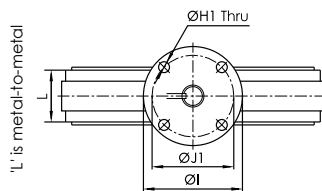

Top View 16" ~ 24"
Wafer & Lug Style

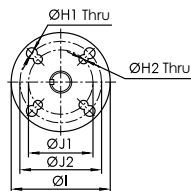

Top View 10" ~ 14"
Wafer & Lug Style

BILL OF MATERIALS (1)

No.	PART	WAFER STYLE	LUG STYLE
1	Stem	T-410 SS	T-410 SS
2	Bushing	PTFE	PTFE
3	Body	Cast Iron	Ductile Iron
4	O-Ring	EPDM (2) or Buna-N	EPDM (2) or Buna-N
5	Seat (3)	EPDM (2) or Buna-N	EPDM (2) or Buna-N
6	Pin	T-410 SS	T-410 SS
7	Disc	Bronze or Nickel Plated DI or CF8M T-316 SS	
8	End Cap (4)	Cast Iron	Cast Iron
9	Bolt (4)	Carbon Steel	Carbon Steel
10	Key (5)	Carbon Steel	Carbon Steel
11	Set Screw (4)	Carbon Steel	Carbon Steel

- BOM represents standard materials. Equivalent or better materials may be substituted at the manufacturer's discretion.
- EPDM is sulfur cured.
- Seat is phenolic backed cartridge on sizes 10" ~ 14"
Seat is aluminum backed cartridge on sizes 16" ~ 24".
- Sizes 10" ~ 12" do not have End Cap (#8) or Bolt (#9).
- Sizes 10" ~ 12" have US Standard keys. Sizes 14" ~ 24" have metric keys.
- Part number eleven (Set Screw) is optional and only applies to Lug Style valves when customer specifies valve for dead-end service.

TECHNICAL NOTES

Valves are designed to comply with MSS SP-67 Type II

Valves are tested to comply with API 598

Bolting pattern conforms to Cast Iron ASME B16.1 Class 125 and Ductile Iron ASME B16.42 Class 150 (1)

Top flange drilling conform to ISO 5211

Max working pressure Sizes 2" ~ 12" is 200 PSI Sizes 14" ~ 48" is 150 PSI (1)

Sizes 8" and larger have round style stems

Valves can be made silicone free upon request

Not recommended for steam service (consult factory)

- Bolting pattern for Cast Iron Class 125 and Ductile Iron Class 150 are identical. Pressure ratings are not identical. Valves 2" ~ 12" have a max working pressure of 200 PSI and 14" ~ 48" have a max working pressure of 150 PSI. Pressure ratings are lower for dead-end service (See page six).

WEIGHT DATA (1)

SIZE	10 lb kg	12 lb kg	14 lb kg	16 lb kg	18 lb kg	20 lb kg	24 lb kg
Wafer Style	54.0 24.5	88.2 40.0	98.0 44.5	162.0 73.5	188.0 85.3	341.8 155.0	529.2 240.0
Lug Style	80.0 36.3	110.0 49.9	130.0 59.0	220.0 99.8	232.0 105.2	322.0 146.1	522.0 236.8

DIMENSIONAL DATA (1)

SIZE in mm	A in mm	B in mm	C in mm	D in mm	E in mm	F in mm	G Deg.	H1 in mm	H2 in mm	I in mm	J1 in mm	J2 in mm	L in mm	M (2) UNC	N (2) Qty	O (3) in mm	P in mm	Q in mm	S x U in mm
10 250	7.99 203	11.50 292	1.50 38	1.13 28.6	14.25 361.95	0.94 23.80	15 ---	0.55 14	0.45 11.5	5.91 150	4.02 102	4.92 125	2.60 66	7/8 - 9 ---	12 12	9.49 241	11.52 292.5	9.80 248.9	--- 8 x 36.2 (4)
12 300	9.53 242	13.27 337	1.87 47	1.25 31.8	17.00 431.8	0.94 23.80	15 ---	0.55 14	0.45 11.5	5.91 150	4.02 102	4.92 125	2.99 76	7/8 - 9 ---	12 12	11.46 291	13.55 344.2	11.81 299.9	--- 8 x 36.2 (4)
14 350	11.02 280	14.49 368	1.77 45	1.25 31.8	18.75 476.25	1.06 27.0	15 ---	0.55 14	0.45 11.5	5.91 150	4.02 102	4.92 125	2.99 76	1 - 8 ---	12 12	12.80 325	14.78 375.3	13.06 331.7	--- 8 x 36.2 (4)
16 400	12.20 310	15.75 400	1.77 45	1.31 33.3	21.25 539.75	1.06 27.0	11.25 ---	0.87 22	n/a n/a	8.27 210	6.50 165	n/a n/a	3.39 86	1 - 8 ---	16 16	14.96 380	17.30 439.5	15.26 387.5	--- 10 x 50
18 450	13.58 345	16.61 422	2.01 51	1.50 38.1	22.75 577.85	1.25 31.80	11.25 ---	0.87 22	n/a n/a	8.27 210	6.50 165	n/a n/a	4.13 105	1 1/8 - 7 ---	16 16	16.85 428	19.31 490.5	17.26 438.4	--- 10 x 50
20 500	14.88 378	18.86 479	2.52 64	1.63 41.3	25.00 635	1.25 31.80	9 ---	0.87 22	n/a n/a	8.27 210	6.50 165	n/a n/a	5.12 130	1 1/8 - 7 ---	20 20	18.66 474	21.08 535.4	19.28 489.6	--- 10 x 50
24 600	18.11 460	22.13 562	2.76 70	2.00 50.8	29.50 749.3	1.37 34.9	9 ---	0.87 22	n/a n/a	8.27 210	6.50 165	n/a n/a	5.94 151	1 1/4 - 7 ---	20 20	22.64 575	25.76 654.4	23.23 590.1	--- 16 x 56

- Dimensions and weights are for reference only. When required, request certified drawings. Weights for 10" ~ 24" include gear operator.
- Dimensions 'M' and 'N' only are applicable to Lug Style valves. Dimension 'M' is Unified Inch Screw Thread, coarse pitch series (UNC) per ANSI B1.1. 'N' is number of bolt holes.
- Dimension 'O' is disc chordal dimension at valve face.
- Sizes 10" through 14" have a Woodruff Mounting Key. Contact factory for additional mounting dimensions and information for these sizes.



> 290 Corporate Drive > Lumberton, NC 28358
> 910-735-0000 T > 910-738-3848 F

www.titanfci.com
titan@titanfci.com

BF 75 & BF 76 > Sizes: 30" ~ 48"

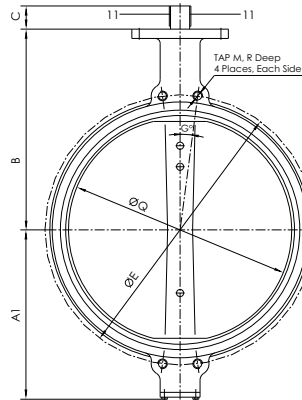

Front View
BF 75 > Wafer Style

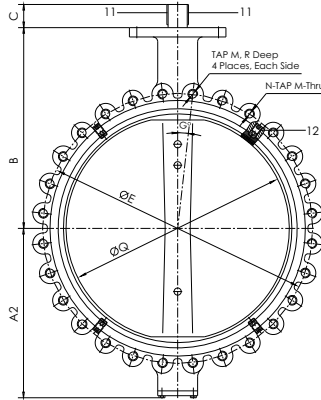

Front View
BF 76 > Lug Style

Part #12 is optional

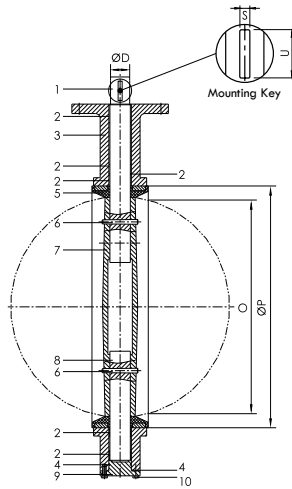

Side View
Wafer & Lug Style

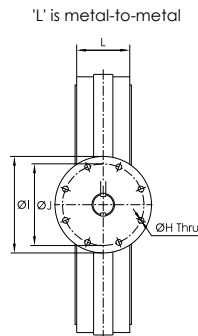

Top View
Wafer & Lug Style

BILL OF MATERIALS (1)

No.	PART	WAFER STYLE	LUG STYLE
1	Upper Stem	T-410 SS	T-410 SS
2	Bushing	PTFE	PTFE
3	Body	Cast Iron	Ductile Iron
4	O-Ring	EPDM (2) or Buna-N	EPDM (2) or Buna-N
5	Seat (3)	EPDM (2) or Buna-N	EPDM (2) or Buna-N
6	Pin	T-410 SS	T-410 SS
7	Disc	Bronze or Nickel Plated DI or CF8M T-316 SS	
8	Lower Stem	T-410 SS	T-410 SS
9	End Cap	Cast Iron	Ductile Iron
10	Bolt	Carbon Steel	Carbon Steel
11	Key	Carbon Steel	Carbon Steel
12	Set Screw (4)	Carbon Steel	Carbon Steel

- BOM represents standard materials. Equivalent or better materials may be substituted at the manufacturer's discretion.
- EPDM is sulfur cured.
- Seat is aluminum backed cartridge on sizes 30" ~ 48".
- Sizes 30" ~ 48" have metric keys.
- Part number twelve (Set Screw) is optional and only applies to Lug Style valve when customer specifies valve for dead-end service. Part number twelve is not included with standard valves.

TECHNICAL NOTES

Valves are designed to comply with MSS SP-67 Type II

Valves are tested to comply with API 598

Bolting pattern conforms to Cast Iron ASME B16.1 Class 125 and Ductile Iron ASME B16.42 Class 150 (1)

Top flange drilling conform to ISO 5211

Max working pressure: 2" ~ 12" is 200 PSI 14" ~ 48" is 150 PSI (1)

Sizes 2" ~ 6" have Double 'D' stems, Sizes 8" ~ 48" have round stems

Valves can be made silicone free upon request

Not recommended for steam service (consult factory)

- Bolting pattern for Cast Iron Class 125 and Ductile Iron Class 150 are identical. Pressure ratings are not identical. Valves 2" ~ 12" have a max working pressure of 200 PSI and 14" ~ 48" have a max working pressure of 150 PSI. Pressure ratings are lower for dead-end service.

WEIGHT DATA (1)

SIZE	30 lb kg	36 lb kg	42 lb kg	48 lb kg
Wafer Style	837.9 380.0	1301.0 590.0	1775.0 805.0	2646.0 1200.0
Lug Style	1036.4 470.0	1697.9 770.0	2183.0 990.0	3307.5 1500.0

DIMENSIONAL DATA (1)

SIZE	A1	A2	B (2)	C	D	E	G	H	I	J	L	M (3)	N (3)	R (3)	O (4)	P	Q	S x U
in mm	in mm	in mm	in mm	in mm	in mm	in mm	Deg.	in mm	in mm	in mm	in mm	UNC	in mm	in mm	in mm	in mm	in mm	in mm
30	20.39	24.61	25.47	2.83	2.17	36	6.43 °	0.71	11.81	10.00	6.57	1 1/4 - 7	28	1.57	28.58	31.29	29.19	- - -
750	518	625	647	72	55	914.4	- - -	18	300	254	167	- - -	28	40	726	794.7	741.3	16 x 63
36	25.31	24.33	30.24/26.69	3.03	2.95	42.75	5.63 °	0.71	11.81	10.00	8.15	1 1/2 - 6	32	1.77	33.03	37.28	33.90	- - -
900	643	618	768/678	77	75	1085.9	- - -	18	300	254	207	- - -	32	45	839	947	861	20 x 70
42	30.31	30.31	33.86	3.35	3.35	49.5	5.00 °	0.71	11.81	10.00	10.08	1 1/2 - 6	36	1.97	39.25	44.27	40.41	- - -
1050	770	770	860	85	85	1257.3	- - -	18	300	254	256	- - -	36	50	997	1124.5	1026.4	22 x 70
48	33.46	33.46	37.01	5.91	3.62	56.00	4.09 °	0.87	13.78	11.73	10.87	1 1/2 - 6	44	2.17	44.29	49.77	45.52	- - -
1200	850	850	940	150	92	1422.4	- - -	22	350	298	276	- - -	44	55	1125	1264.1	1156.1	25 x 140

1. Dimensions and weights are for reference only. When required, request certified drawings. Weights for 30" ~ 48" include gear operator.

2. Dimension 'B' is the same on both Wafer and Lug Styles except on the 36". On the 36" Wafer Style, Dimension B is 30.24 in (768 mm); On the 36" Lug Style, Dimension 'B' is 26.69 in (678 mm).

3. Dimension 'N' is applicable to Lug Style valves. Dimension 'M' is Unified Inch Screw Thread, coarse pitch series (UNC) per ANSI B1.1.

4. Dimension 'O' is disc chordal dimension at valve face.



Valve Handles Sizes: 2" ~ 12"

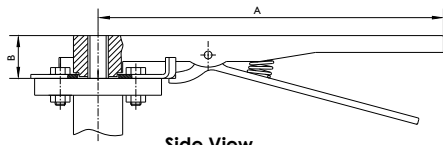

Side View
Sizes 2" ~ 6"

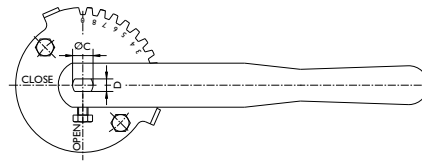

Top View
Sizes 2" ~ 6"

Handles and mounting plates have holes drilled in them which can be used to lock the valve in the open or closed position.

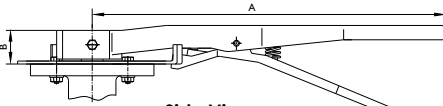

Side View
Sizes 8" ~ 12"

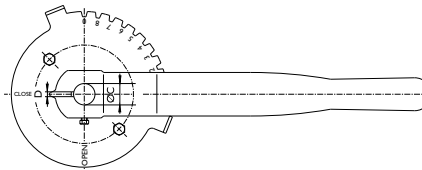

Top View
Sizes 8" ~ 12"

DIMENSIONAL DATA ⁽¹⁾					
SIZE in mm	A in mm	B in mm	C in mm	D in mm	Weight lb kg
2 ~ 3	10.51	1.26	0.50	0.38	3.00
50 ~ 75	267	32	12.7	9.53	1.36
4	10.51	1.26	0.63	0.44	3.00
100	267	32	15.88	11.13	1.36
5 ~ 6	10.51	1.26	0.75	0.50	3.00
125 ~ 150	267	32	19.05	12.7	1.36
8	14.02	1.50	0.88	- - -	5.00
200	356	38	22.23	5	2.27
10	14.02	1.50	1.13	- - -	5.00
250	356	38	28.58	8	2.27
12	14.02	1.50	1.25	- - -	5.00
300	356	38	31.75	8	2.27

1. Dimensions and weights are for reference only. When required, request certified drawings.

Titan FCI makes every effort to ensure the information presented on our literature accurately reflects exact product specifications. However, as changes occur, there may short-term differences between actual product specifications and the information shown on our literature. Titan FCI reserves the right to make specification changes to improve our products without prior notification.

Gear Operators Sizes: 2" ~ 18"

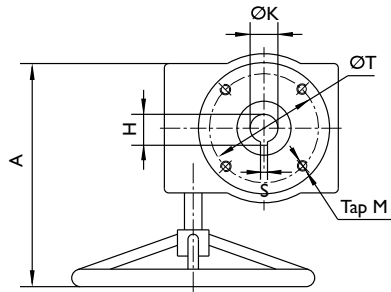

Top View
Sizes 2" ~ 18"

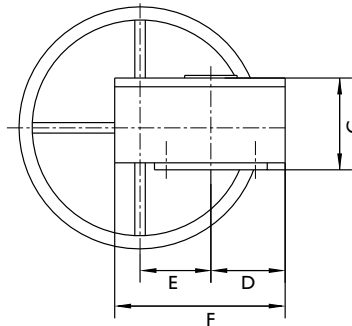

Back View
Sizes 2" ~ 18"

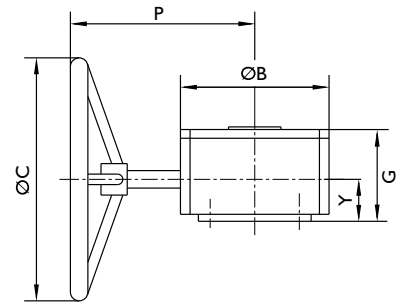

Side View
Sizes 2" ~ 18"

DIMENSIONAL DATA ⁽¹⁾																	
SIZE in mm	A in mm	B in mm	C in mm	D in mm	E in mm	F in mm	G in mm	P in mm	Y in mm	K in mm	H in mm	S in mm	T in mm	M in mm	Weight lb kg	Torque lb-in N-m	Ratio
2 ~ 3	9.06	4.13	5.91	2.09	1.77	4.92	2.44	7.01	1.50	0.50	0.56	- - -	1.97	- - -	13.23	1505	24:1
50 ~ 75	230	105	150	53	45	125	62	178	38	12.7	14.1	3	50	M6	6.00	170	
4	9.06	4.13	5.91	2.09	1.77	4.92	2.44	7.01	1.50	0.63	0.72	- - -	2.76	- - -	13.23	1505	24:1
100	230	105	150	53	45	125	62	178	38	15.9	18.2	5	70	M8	6.00	170	
5 ~ 6	9.06	4.13	5.91	2.09	1.77	4.92	2.44	7.01	1.50	0.75	0.84	- - -	2.76	- - -	13.23	1505	24:1
125 ~ 150	230	105	150	53	45	125	62	178	38	19.05	21.35	5	70	M8	6.00	170	
8	12.20	6.22	11.81	2.99	2.48	6.85	3.07	9.25	1.65	0.87	0.96	- - -	4.02	- - -	30.86	6638	30:1
200	310	158	300	76	63	174	78	235	42	22.2	24.5	5	102	M10	14.00	750	
10	12.2	6.22	11.81	2.99	2.48	6.85	3.07	9.25	1.65	1.13	1.26	- - -	4.02	- - -	30.86	6638	30:1
250	310	158	300	76	63	174	78	235	42	28.6	31.9	8	102	M10	14.00	750	
12 ~ 14	12.01	6.69	11.81	3.19	3.19	7.68	3.15	8.90	1.61	1.25	1.38	- - -	4.02	- - -	35.27	10621	50:1
300 ~ 350	305	170	300	81	81	195	80	226	41	31.8	35.1	8	102	M10	16.00	1200	
16	12.48	8.27	14.17	4.92	3.74	10.01	4.13	8.54	1.89	1.31	1.44	- - -	6.50	- - -	99.21	22127	80:1
400	317	210	360	125	95	255	105	217	48	33.3	36.6	10	165	M20	45.00	2500	
18	12.48	8.27	14.17	4.92	3.74	10.04	4.13	8.54	1.89	1.50	1.63	- - -	6.50	- - -	99.21	22127	80:1
450	317	210	360	125	95	255	105	217	48	38.1	41.4	10	165	M20	45.00	2500	

1. Dimensions and weights are for reference only. When required, request certified drawings.



Gear Operators Sizes 20" ~ 24"

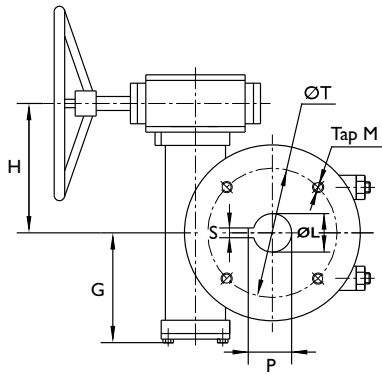

Top View
Sizes 20" ~ 24"

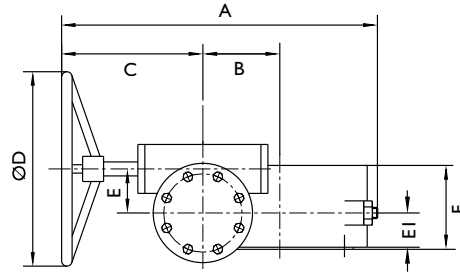

Side View
Sizes 20" ~ 24"

DIMENSIONAL DATA ⁽¹⁾

SIZE in mm	A in mm	B in mm	C in mm	D in mm	E in mm	E1 in mm	F in mm	G in mm	H in mm	T in mm	N/M in mm	L in mm	S in mm	P in mm	Weight lb kg	Torque lb-in N-m	Ratio
20	18.90	4.33	8.27	14.17	2.48	2.05	4.72	6.30	7.28	6.50	- - -	1.63	- - -	1.76	143.30	26552	352:1
500	480	110	210	360	63	52	120	160	185	165	M20	41.3	10	44.6	65	3000	
24	20.47	4.92	8.27	14.17	2.48	2.24	4.72	6.30	7.28	6.50	- - -	2.00	- - -	2.17	158.73	35403	416:1
600	520	125	210	360	63	57	120	160	185	165	M20	50.8	16	55.1	72	4000	

1. Dimensions and weights are for reference only. When required, request certified drawings.

Stem Extensions & Chain Wheels

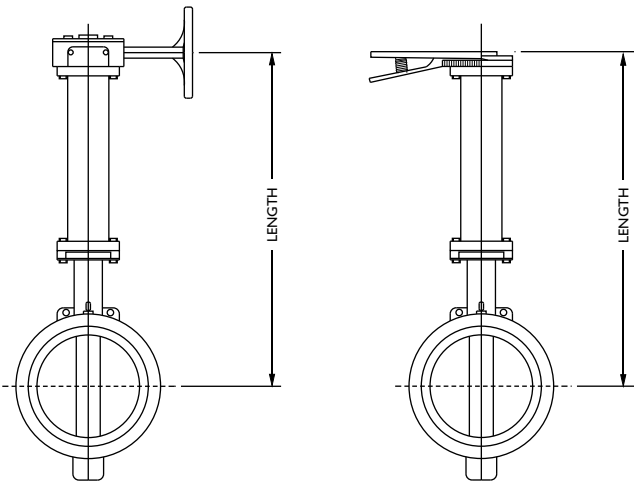

> Stem Extensions

Stem extensions are utilized to elevate the operating location of the butterfly valve. The top mounting pad of the stem extension provides the same dimensions as the valve's mounting pad. This ensures a universal mounting flange that can accommodate all types of operators (10-position handle kits, gear operators, electric actuators, or pneumatic actuators).

Stem Extensions can be fabricated from carbon or stainless steel and range in length from three inches to sixteen feet. Beyond the upper limit, the structural integrity of the valve stem becomes a factor and requires special design consideration. Please contact the factory direct for pre-sales design assistance.

> Chain Wheels

The primary purpose of a chain wheel actuator is to provide ground level control of hard-to-reach valves. This capability saves time and helps minimize the risk of personal injury during valve operations. Chain wheels are available in a variety of materials and configurations. Please contact the factory so we can recommend the appropriate chain wheel configuration for your specific application.

The picture to the right shows how an adjustable sprocket rim can be fastened to the round hand wheel of a gear operator.

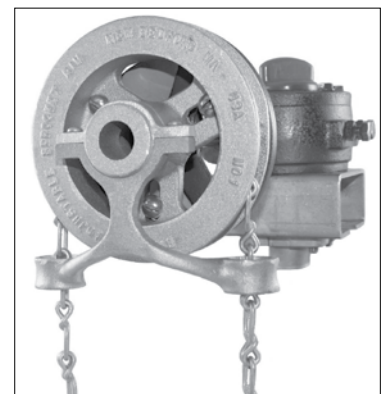

Butterfly Valve Seating and Unseating Valve Torque Ratings

Valve Sizes		Full Rated Pressure Ratings (Torque for psi is expressed as in-lb, Torque for MPa is expressed as N-m)										Correction Factors
in	mm	50 psi	0.4 MPa	100 psi	0.6 MPa	150 psi	1.0 MPa	200 psi	1.4 MPa	250 psi	1.6 MPa	
2	50	99	10	105	14	111	14	117	13	121	15	The following guidelines may be used to estimate torque values for other types of service. For Dry Service: Multiply by 160% For Lubricated Service: Multiply by 85% For Actuator Sizing: First apply the correction factor for the type of service then use the additional correction factors Multiply by 150% (Single Valve Application) Multiply by 200% (Three way applications)
2.5	65	150	15	163	21	175	23	189	21	196	24	
3	80	206	20	219	28	232	30	243	27	250	30	
4	100	289	28	322	42	357	46	389	43	410	50	
5	125	422	41	481	62	540	70	597	66	643	78	
6	150	598	58	690	90	782	102	874	97	935	114	
8	200	1059	103	1182	154	1306	170	1429	159	1517	185	
10	250	1670	163	1872	243	2074	269	2275	253	2403	292	
12	300	2568	250	2794	363	3023	392	3248	361	3401	414	
14	350	2639	257	3069	399	3500	454	3964	441	4267	519	
16	400	4260	415	4879	634	5500	714	5987	666	6280	764	
18	450	6287	612	7243	940	8199	1065	9183	1022	9817	1195	
20	500	8360	814	9180	1192	10000	1298	10859	1208	11409	1389	
24	600	15427	1502	16813	2183	18200	2363	18728	2084	19155	2332	
30	750	27313	2660	29407	3818	31500	4090	33530	3731	34844	4241	
36	900	54667	5323	57034	7405	59399	7712	61793	6877	63351	7711	
42	1050	82460	8030	86034	11170	89600	11633	---	---	---	---	
48	1200	108015	10518	112704	14633	117376	15239	122101	13588	125177	15236	

The above torques are for reference only. They were calculated from test data using clean, wet fluids (i.e. water) at ambient temperatures during on/off service. During actual service, hydrodynamic torque may meet or exceed the above listed seating and unseating torques. Therefore, hydrodynamic torque must be considered during system design to ensure proper valve and actuator selection. As always, a Titan FCI application engineer is ready to assist with valve and actuator selection.

Pressure Ratings (Bidirectional)

2" ~ 12"	200 psig	14 bar
14" ~ 24"	150 psig	10 bar

Butterfly Valve is mated between two flanges for bidirectional service and the disc is in the closed position.

Pressure Ratings (Dead-End)

2" ~ 12"	150 psig	10 bar
14" ~ 24"	100 psig	7 bar

Butterfly Valve is installed for dead-end service without a downstream flange. Disc is in the closed position. Please note, standard valves are not designed for dead-end service. Dead-end service must be specified by the customer.

Flow Rate Limits (On/Off Service)

Fluids	20 ft/sec	6 m/sec
Gases	175 ft/sec	54 m/sec

This table lists velocity limits for on/off services only. Additionally, for throttling service, the flow velocity should not exceed 20 ft/sec for liquids and 175 ft/sec for gases.

Seat Material Temperature Ratings

Buna-N	+10 ~ 180 °F	-12 ~ 82 °C
EPDM	-30 ~ 225 °F	-34 ~ 107 °C

This table lists the theoretical temperature limits for elastomers. During actual service, hardening of the elastomer may cause the torque to exceed the structural limits of the valve.

Butterfly Valve C_v Flow Coefficient Values (GPM @ 1ΔP)

Valves Sizes		Angle of Valve Disc Rotation								
in	mm	10°	20°	30°	40°	50°	60°	70°	80°	90°
2	50	0.06	3	7	15	27	44	70	105	115
2.5	65	0.10	6	12	25	45	75	119	178	196
3	80	0.20	9	18	39	70	116	183	275	302
4	100	0.30	17	36	78	139	230	364	546	600
5	125	0.50	29	61	133	237	392	620	930	1022
6	150	0.80	45	95	205	366	605	958	1437	1579
8	200	2	89	188	408	727	1202	1903	2854	3136
10	250	3	151	320	694	1237	2049	3240	4859	5340
12	300	4	234	495	1072	1911	3162	5005	7507	8250
14	350	6	338	715	1549	2761	4568	7230	10844	11917
16	400	8	464	983	2130	3797	6282	9942	14913	16388
18	450	11	615	1302	2822	5028	8320	13168	19752	21705
20	500	14	791	1647	3628	6465	10698	16931	25396	27908
24	600	22	1222	2587	5605	9989	16528	26157	39236	43116
30	750	37	2080	4406	9546	17010	28147	44545	66818	73246
36	900	260	3050	6730	12740	20220	32500	52500	79600	87500
40	1000	313	3665	8089	15942	2429	39056	63093	95660	105154
42	1050	350	4095	9040	17108	27150	43640	70500	106890	117500
48	1200	455	5365	11840	22400	30600	51200	92300	140000	154000

This chart can be used as a guide only due to the numerous variations of flow conditions that may occur during actual service.

C_v Equation For Liquids

$$C_v = Q * \sqrt{\frac{G}{\Delta P}}$$

C_v = Flow Coefficient

G = Specific Gravity of liquid at 60 °F

Q = Flow rate in U.S. gallons per minute (GPM)

ΔP = Pressure drop in pounds per square inch (PSI)

The Flow Coefficient (designated as C_v) is a physical measurement that specifies the number of gallons per minute (GPM) that can pass through a piping component, at room temperature, and create a one (1) psi differential (ΔP) across the piping component.

HOW TO ORDER

Series	Code	Body Material	Code	Stem Material	Code	Disc Material	Code	Seat Material	Code	Actuator	Code
200 PSI Wafer Type	BF75	Cast Iron *	CI	Stainless Steel * Type 410	R	Nickle Plated * Ductile Iron	D	Buna-N *	B	Bare Stem	O
200 PSI Lug Type	BF76	Ductile Iron *	DI	Stainless Steel Type 316	S	Aluminum * Bronze	B	EPDM *	E	10 Position Handle	L
200 PSI Lug Type Dead End Service	BF76D	Carbon Steel	CS			Stainless Steel * Type 316	S	Viton	V	Infinite Handle	I
		Stainless Steel	SS			Special	X	Teflon	T	Gear Operator	G
								Special	X	Chain Wheel	C
										Actuated	A

Notes:

1. Not all configurations are readily available. Please contact factory. (*) Denotes standard materials.
2. Other seat materials can be provided. Please contact factory.
3. Other body materials can be provided. Please contact factory.

ORDERING EXAMPLE:

PART NUMBER: 8.0-BF75-CI-R-B-B-G

DESCRIPTION: 8" Wafer Style Butterfly Valve, Cast Iron Body, 410 Stainless Steel Stem, Bronze Disc, Buna-N Seat, and Gear Operator

Flange Bolting Information

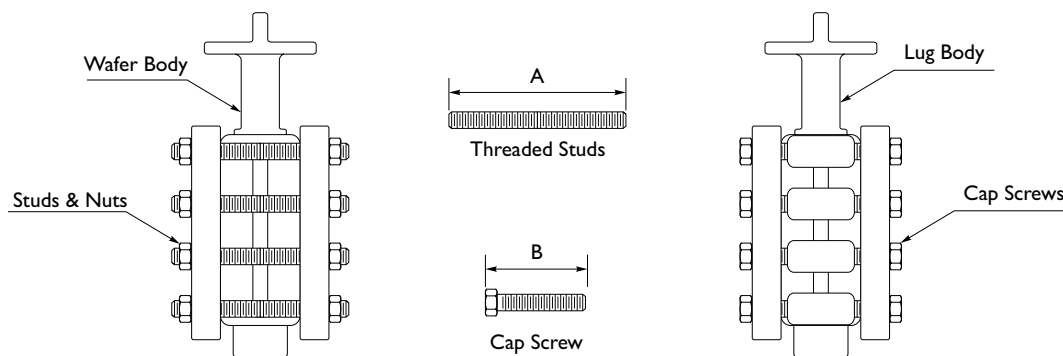
WAFER STYLE FLANGE BOLT DATA - WITH THREADED STUDS ⁽¹⁾

Valve Size	Quantity Per Valve	Bolt Size	Stud Bolt Length "A"
2	4	5/8" - 11	4.75
2.5	4	5/8" - 11	5.25
3	4	5/8" - 11	5.25
4	8	5/8" - 11	5.5
5	8	3/4" - 10	6
6	8	3/4" - 10	6
8	8	3/4" - 10	6.5
10	12	7/8" - 9	7
12	12	7/8" - 9	7.75
14	12	1" - 8	8.25
16	16	1" - 8	8.75
18	16	1 1/8" - 7	10
20	20	1 1/8" - 7	11
24	20	1 1/4" - 7	12.75

1. Flange bolting information is in accordance with ASME 16.5 Class 150 specifications.

LUG STYLE FLANGE BOLT DATA - WITH CAP SCREWS ⁽¹⁾

Valve Size	Quantity Per Valve	Bolt Size	Cap Screw Length "B"
2	8	5/8" - 11	1.25
2.5	8	5/8" - 11	1.5
3	8	5/8" - 11	1.5
4	16	5/8" - 11	1.75
5	16	3/4" - 10	1.75
6	16	3/4" - 10	1.75
8	16	3/4" - 10	2
10	24	7/8" - 9	2.25
12	24	7/8" - 9	2.5
14	24	1" - 8	2.75
16	32	1" - 8	3
18	32	1 1/8" - 7	3.5
20	40	1 1/8" - 7	4
24	40	1 1/4" - 7	4.75

1. Flange bolting information is in accordance with ASME 16.5 Class 150 specifications.