



TITAN FLOW CONTROL, INC.

## "Y" (WYE) STRAINER ♦ THREADED ENDS

### ALUMINUM BRONZE ♦ ANSI CLASS 250 ♦ LEAD FREE (1)

Meets LEAD-FREE<sup>(1)</sup> requirements!

MODELS: **YS 52-AB**  
(ALUMINUM BRONZE)

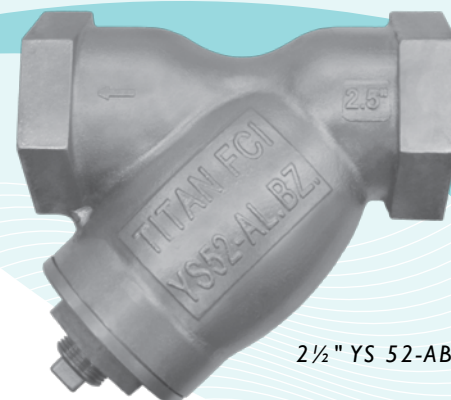

2 1/2" YS 52-AB

## FEATURES

SIZE RANGE : 1/4" ~ 3"

### ♦ ASTM B148 BODY MATERIAL

ALUMINUM BRONZE IS STRONGER AND LESS LIKELY TO CORRODE THAN OTHER BRONZE ALLOYS, MAKING THEM A PREFERRED CHOICE FOR SEA WATER AND OTHER APPLICATIONS WHERE CORROSION IS A CONCERN. BECAUSE OF ITS COPPER CONTENT, MARINE ORGANISMS CANNOT COLONIZE ON THE MATERIAL. ADDITIONALLY, TITAN'S YS52-AB IS USED FOR POTABLE WATER APPLICATIONS AS IT MEETS LEAD FREE STATUTES REQUIRING THAT THE LEAD CONTENT IN THE WETTED SURFACES IS 0.25% OR LESS AS DETERMINED BY A WEIGHTED AVERAGE.

### ♦ LARGE STRAINING CAPACITY

WITH ITS LARGE BODY AND SIZABLE STRAINING ELEMENT, THE YS52 PROVIDES EXCELLENT OPEN AREA RATIOS THAT ARE TYPICALLY TWO-AND-A-HALF TIMES LARGER THAN THE CORRESPONDING PIPELINE, MINIMIZING PRESSURE DROP ACROSS THE VALVE.

### ♦ PRECISION MACHINED SEATS

PRECISION MACHINED SCREEN SEATS IN BOTH THE BODY AND CAP HELP TO ENSURE ACCURATE POSITIONING OF THE SCREEN DURING REASSEMBLY AFTER CLEANING. ALSO, THE MACHINED BODY SEATS ENABLE FINER FILTRATION BY PREVENTING DEBRIS BYPASS.

### ♦ SELF-CLEANING CAPABILITY

WITH A TAPPED NPT BLOW-OFF CONNECTION, THIS UNIT CAN BE FITTED WITH A BLOW-DOWN VALVE WHICH FACILITATES CLEANING OF THE STRAINING ELEMENT. PLEASE CONTACT FACTORY FOR MORE INFORMATION.

## TECHNICAL

PRESSURE/TEMPERATURE RATING <sup>(2)</sup>  
AB - ASTM B148 GR. 9D - CLASS 250  
**YS 52-AB (THREADED)**

WOG (Non-shock): 400 PSI @ 150 °F  
Saturated Steam: 250 PSI @ 406 °F  
Maximum Liquid: 250 PSI @ 400 °F

1. The YS 52-AB meets requirements for lead free use in potable water systems. The lead content in the wetted surfaces is 0.25% or less as determined by a weighted average. For more information on lead free requirements, contact Titan Flow Control, Inc.
2. The above listed temperatures are theoretical and may vary during actual operating conditions.

## APPLICATIONS

**GENERAL APPLICATION:** Y-STRAINERS ARE INSTALLED IN A PIPING SYSTEM TO REMOVE UNWANTED DEBRIS FROM THE PIPELINE, PROTECTING EXPENSIVE EQUIPMENT DOWNSTREAM SUCH AS PUMPS, METERS, SPRAY NOZZLES, COMPRESSORS, AND TURBINES. THEY CAN BE PLACED IN A HORIZONTAL OR VERTICAL PIPELINE AS LONG AS THE SCREEN IS IN A DOWNWARD POSITION. STRAINING IS ACCOMPLISHED VIA AN INTERNAL PERFORATED OR MESH LINED STRAINING ELEMENT, THE SIZE OF WHICH SHOULD BE DETERMINED BASED ON THE SIZE OF THE SMALLEST PARTICLE TO BE REMOVED.

**SERVICING:** THE STRAINING ELEMENT NEEDS REGULAR CLEANING TO PREVENT DEBRIS BUILD UP. IT IS NOT ADVISABLE TO ALLOW THE DIFFERENTIAL PRESSURE TO INCREASE BY 20 PSI. ALTHOUGH CLEANING NORMALLY REQUIRES THE REMOVAL OF THE STRAINING ELEMENT, INSTALLING AND USING A TITAN BLOW-OFF DRAIN VALVE CAN INCREASE THE TIME BETWEEN CLEANINGS.

*The above data represents common market and service applications. No representation or guarantee, expressed or implied, is given due to the numerous variations of concentrations, temperatures and flow conditions that may occur during actual service.*

## TITAN FLOW CONTROL, INC.

YOUR PIPELINE TO THE FUTURE!

Tel: 910-735-0000 ♦ Fax: 910-738-3848 ♦ titan@titanfci.com ♦ www.titanfci.com  
290 Corporate Drive ♦ PO Box 7408 ♦ Lumberton, NC 28358



**TITAN FLOW CONTROL, Inc.**  
 290 Corporate Drive  
 Lumberton, NC 28358  
 Tel: 910.735.0000  
 E-mail: titan@titanfci.com  
 Web: www.titanfci.com  
 Fax: 910.738.3848

**"Y" (WYE) STRAINER**  
**YS 52-AB - (Threaded)**

ANSI Class  
 250

Threaded Ends • ANSI Class 250 • Aluminum Bronze

**BILL OF MATERIALS <sup>(1)</sup>**

No.	PART	YS 52 - AB
1	Body	Aluminum Bronze ASTM B148 Gr. 9D
2	Cap	Aluminum Bronze ASTM B148 Gr. 9D
3	Straining Element <sup>(2)</sup>	Stainless Steel
4	Gasket <sup>(2)</sup>	Teflon
5	NPT Plug (Blow-off)	Aluminum Bronze ASTM B148 Gr. 9D

Illustrations are representative of YS 52-AB (Threaded-end connections). Please ask for certified drawings when required.

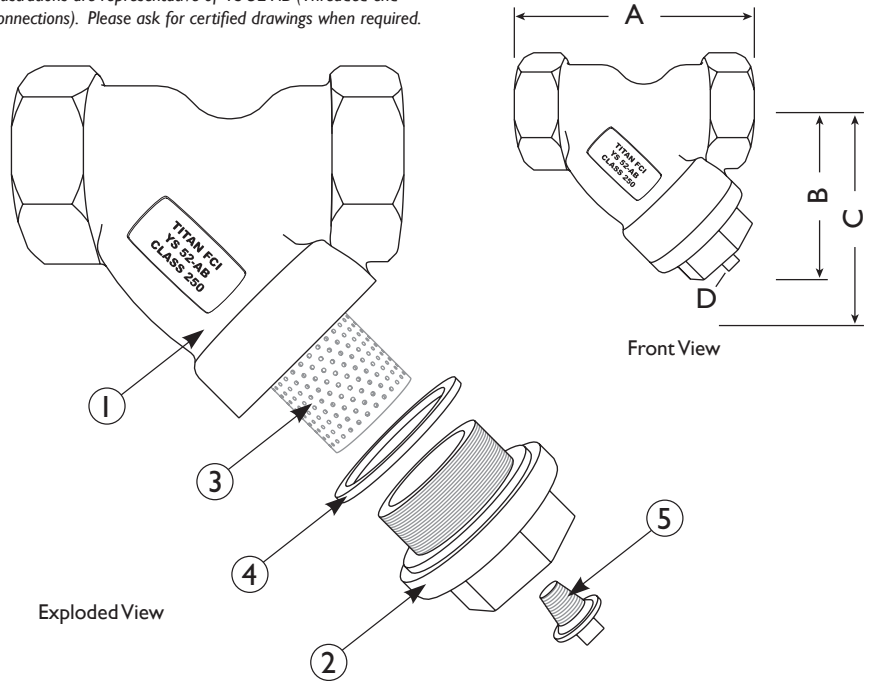

1. Bill of Materials represents standard materials. Equivalent or better materials may be substituted at the manufacturer's discretion.
2. Denotes recommended spare parts.

**Body Material Application Notes:**

- Aluminum Bronze (ASTM B148) is a preferred material for lead-free wye strainers, meeting requirements for potable water systems by containing 0.25% lead or less by average weight on all wetted parts.
- Aluminum Bronze is strong and corrosion resistant, meeting the needs of many various applications, such as seawater and marine.

**DIMENSIONS AND PERFORMANCE DATA <sup>(1)</sup>**

SIZE	in	1/4	3/8	1/2	3/4	1	1 1/4	1 1/2	2	2 1/2	3
	mm	8	10	15	20	25	32	40	50	65	80
<b>A DIMENSION</b> FACE TO FACE <sup>(2)</sup>	in	2.75	2.75	2.75	3.00	3.75	4.43	5.00	5.68	9.00	9.00
	mm	70	70	70	76	95	113	127	144	229	229
<b>B DIMENSION</b> CENTER LINE TO BOTTOM	in	2.18	2.18	2.18	2.34	2.91	3.5	3.78	4.39	6.44	6.44
	mm	55	55	55	59	74	89	96	112	164	164
<b>C DIMENSION</b> SCREEN REMOVAL	in	4.00	4.00	4.00	4.25	4.75	5.25	6.00	7.00	10.00	10.00
	mm	102	102	102	108	121	133	152	178	254	254
<b>D NPT Plug</b> BLOW-OFF	in	1/4	1/4	1/4	1/4	3/8	3/4	3/4	1	1 1/4	1 1/4
	mm	8	8	8	8	10	20	20	25	32	32
APPROXIMATE ASSEMBLED WEIGHT	lb	0.5	0.5	0.5	1.0	1.8	2.5	4.0	5.6	15.9	15.9
	kg	0.2	0.2	0.2	0.5	0.8	1.1	1.8	2.5	7.2	7.2
Flow Coefficient	C <sub>v</sub>	0.7	2	8	15	22	38	42	70	110	160

1. Dimensions and weights are for reference only. When required, request certified drawings.
2. Face to face values have a tolerance of ±0.06 in (±2.0 mm).

**PRESSURE - TEMPERATURE RATINGS**

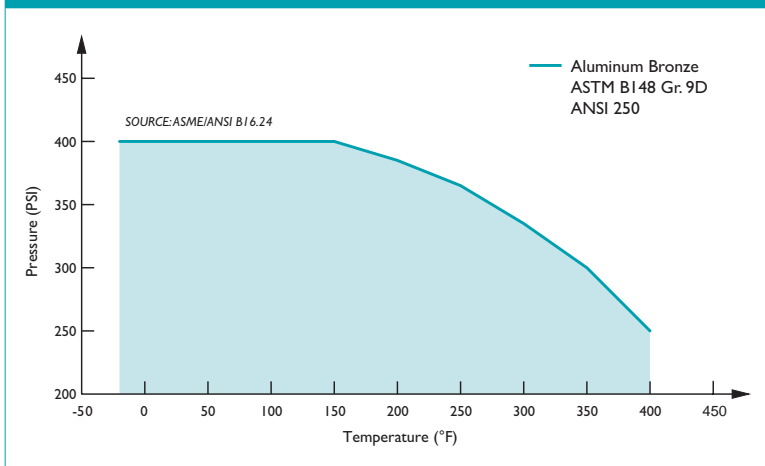

**PRESSURE - TEMPERATURE RATING**

ANSI Class 250	ASTM B148 Gr. 9D
WOG (Non-shock):	400 PSI @ 150 °F
Saturated Steam:	250 PSI @ 406 °F
Max Liquid:	250 PSI @ 400 °F

**STANDARD SCREEN SELECTIONS**

Size	Liquid	Open Area	Steam	Open Area
1/4" ~ 2"	20 mesh	51.8%	30 mesh	44.8%
2 1/2" ~ 3"	1/16 (.0625)	41%	3/64 (.045)	36%

**REFERENCED STANDARDS & CODES**

CODE	DESCRIPTION
ASME/ANSI B16.15	Cast Bronze Threaded Fittings
ASME/ANSI B16.24	Cast Copper Alloy Pipe Flanges and Flanged Fittings

Titan FCI makes every effort to ensure the information presented on our literature accurately reflects exact product specifications. However, as product changes occur, there may be short-term differences between actual product specifications and the information contained within our literature. Titan FCI reserves the right to make design and specification changes to improve our products without prior notification. When required, request certified drawings.