

AS-i Bus System

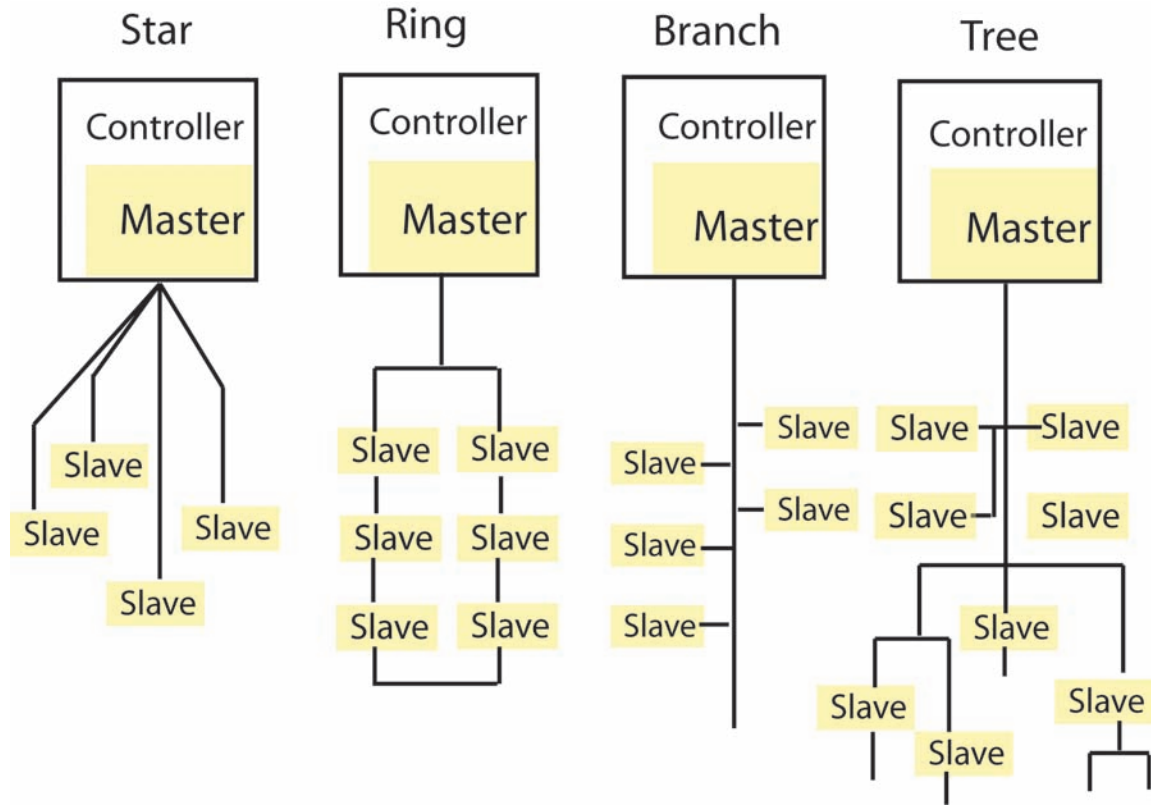

AS-i (Actuator-Sensor Interface) offers many of the benefits of more complex and costly bus systems, but does it at a substantially lower cost and with greater simplicity. The Actuator-Sensor Interface is ideally suited for controlling valves, actuators and many other field devices in your processing application. This interface can be used for stand-alone process control, or it can be used together with a higher-level bus control system. AS-interface does not compete with higher-level bus systems; it should be seen as a complimentary system that offers low cost, reliable device control for binary and analog devices. Reliability, simplicity and interoperability make AS-interface a cost effective connection/control solution, particularly where low installation costs are imperative. A single pair of wires, which handles power and communications, is used to control the network by means of "chaining" the actuators with the PLC. Each actuator (or device) will then have its own unique address within the system and only that device with the proper address will respond to system commands. AS-i is best known for its yellow flat cable, which is pierced by insulation displacement connectors so that the expense of tees and complex connectors is avoided. Devices are simply clamped onto the cable.

Digital signals are encoded on this cable in a sinusoidal signal, which has a very narrow frequency bandwidth. Filtering which is distributed through the network rejects all extraneous frequencies, and in this way AS-i can be operated in electrically noisy environments without experiencing transmission errors. The yellow flat cable carries low current (30 VDC) for input devices as well as the AS-i signal. If power for outputs (such as energizing relays) is required, an additional BLACK flat cable is available. Standard networking is capable of 62 units with a distance up to 100 meters, and a cycle time of 5ms. A maximum of 300 meters is achieved by installing repeaters. This system also responds well with products from other manufacturers, by installing a gateway to "translate" the commands of higher-level networks. This allows an existing system to be expanded simply by using the AS-i networking system. There are various wiring structures that can be used with this system such as the "star", "ring", "branch", "tree", etc. All are practiced and acceptable, but the loop has a distinguished property; if there were a "break" in the network cable the units **would still cycle** and the master would detect the loss of a node. This feature is unique to the ring structure.



AS-i Bus System

Pneumatic Specifications

Mounting: ISO/NAMUR
 Connection: M12 SS
 AS-i Current Draw: .16 AMP
 Electrical Design: 2-input/2-output
 Voltage Range: 26.5-31.6 VDC
 Sensor/Relay Supply: AS-i
 Sensor Protection: Type 4X
 Air Connection: 1/4" FNPT
 Solenoid Coil: Epoxy encapsulated
 Solenoid Protection: Type 4x
 Reverse polarity protected

Standard Features

- Low profile, compact package for ease in mounting where space limitations are an issue.
- Actuators and accessories meet ISO and NAMUR Standards, therefore no special training is required for field installation/conversion.
- M12 SS connection utilized for network interfacing - Type 4X rated.
- No moving parts with proximity sensor triggered by a target puck.
- Sealed proximity switch so open cavity condensation is not an issue.
- Each actuator has visual indication and proximity feedback to the PLC.
- Each component meets Type 4X.
- Low power consumption allows power and data communications via the same two-wire cable.
- A system of 31 valves requires less than 5 amps of AS-i power.
- Expandability with gateway and/or insulation displacement connector.
- 5 ms reaction time from PLC to cycling of unit.
- Conformance to AS-i Certificate ZU15101.

Accessories

- Master/Controller - AS-i
- Master/Controller - Gateway
- Power Supply
- Addressing Unit
- Operating Software
- Yellow Communications Cable
- Black Power Cable
- Displacement Connectors
- Displacement Splitter
- Cable Clip

Sample Specification

All pneumatically actuated AS-interface systems shall have a 2-input/2-output proximity sensor and a solenoid directly mounted to a Series 79 Actuator. The sensor shall be constructed of Pocan[®] Thermoplastic Polyester, Type 4X protection, operation and function LED's, voltage range of 20-30 VDC, and a stainless steel M12 socket connection to the network. The solenoid shall have an anodized aluminum body with a 1/4" NPT air inlet, manual over ride, and Type 4X protection. Spool/piston shall be synthetic resin with NBR and FKM O-rings, and fitted with an epoxy-encapsulated coil directly coupled to the proximity sensor, as supplied by Asahi/America, Inc.

AS-i Bus System

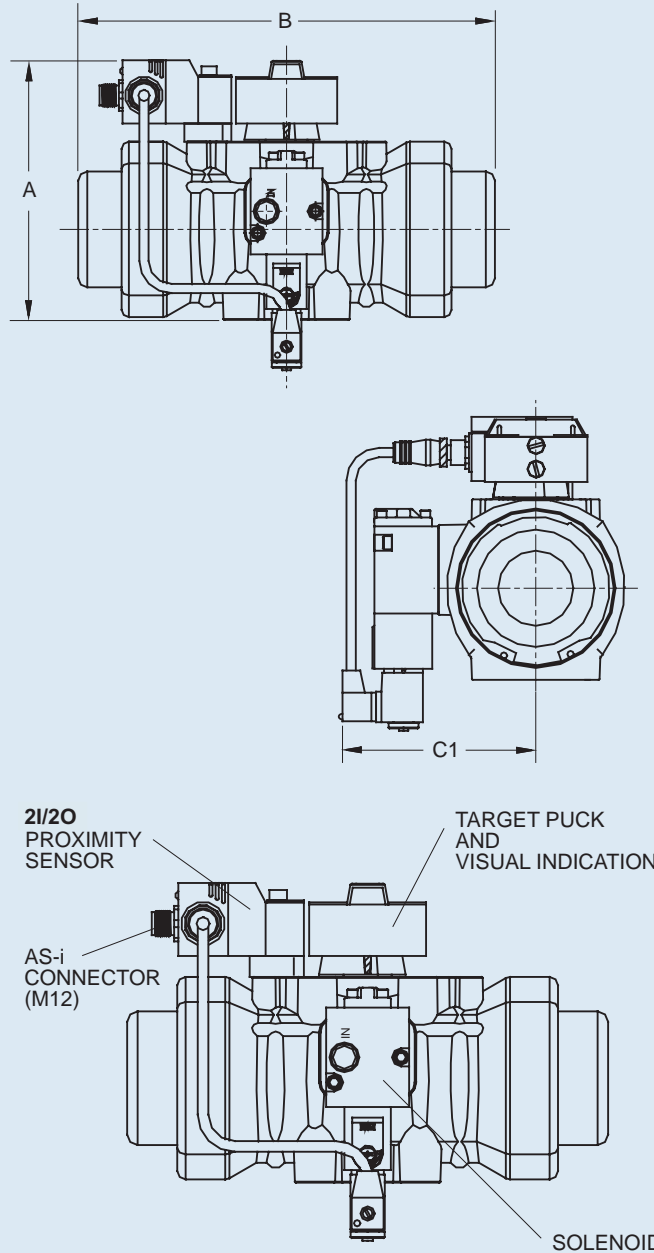

Dimensions (IN.)

Series	A	B	C1
A79PN	4.33	4.29	3.52
A79PSN	4.33	5.65	3.52
B79PN	4.92	4.92	3.78
B79PSN	4.92	6.30	3.78
B579PN	5.39	5.75	4.14
B579PSN	5.39	7.64	4.14
C79PN	5.59	7.16	4.22
C79PSN	5.59	9.29	4.22
C579PN	6.42	7.99	4.41
C579PSN	6.42	10.12	4.41

Dimensions (IN.)

Series	A	B	C1
D79PN	6.93	9.21	4.69
D79PSN	6.93	12.28	4.69
D579PN	8.11	10.87	5.12
D579PSN	8.11	14.25	5.12
E79PN	8.90	13.74	5.75
E79PSN	8.90	18.86	5.75
F79PN	10.51	17.48	6.77
F79PSN	10.51	23.54	6.77
G79PN	12.12	20.63	7.36
G79PSN	12.12	27.32	7.36